

EC Series Self Contained Gourmet Ice Machines –
with Progressive Water Discharge – up to 74kg
ECM 127 AS OX Medium gourmet cube 20g, Ø30mm x 34mm



Medium gourmet cube
20g, 30mm dia x H 34mm



Note: Ice production rate is measured with the water temperature at 10°C and an ambient temperature of 21°C.

- Up to 74kg daily production rate
- 39kg storage bin capacity
- Air cooled version
- Produces individual transparent Gourmet crystal clear supercubes
- Hydrocarbons R290 refrigerant gas
- XSafe - Natural Sanitation System
- PWD-Progressive water discharge: pumps excess residual water up to a distance up to 15 meters
- Agion Technology resists the growth of microbes and the development of unpleasant odours
- Simple, reliable electromechanic controls
- Horizontal ice evaporator spray-system technology
- Resistant stainless steel exterior
- Front access condenser air filter, removable and washable
- Routine maintenance visible alarm light on front panel
- Ergonomically designed ice storage access with disappearing door and door closing movement dampening system
- Includes removable air filter, ice scoop, water and drain hose

EC Series Self Contained Gourmet Ice Machines – with Progressive Water Discharge – up to 74kg

ECM 127 AS OX

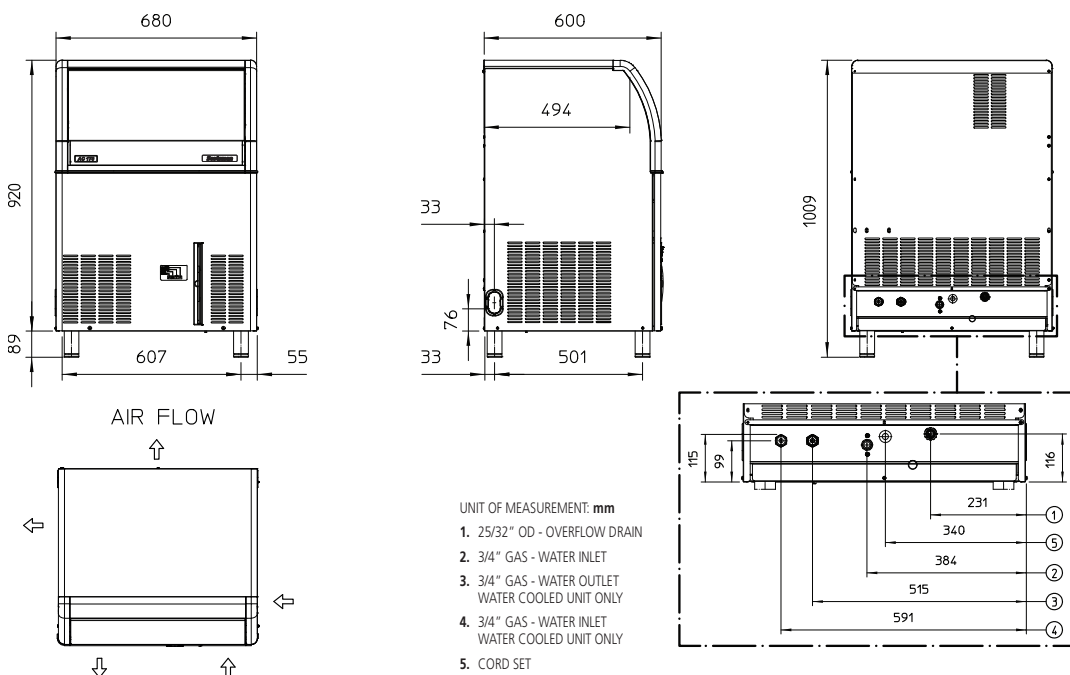

moffat.com.au

Australia
Moffat Pty Limited
Victoria/Tasmania
740 Springvale Road
Mulgrave, Victoria 3170
Telephone 03-9518 3888
Facsimile 03-9518 3833
vsales@moffat.com.au

New South Wales
Telephone 02-8833 4111
nswsales@moffat.com.au

South Australia
Telephone 03-9518 3888
vsales@moffat.com.au

Queensland
Telephone 07-3630 8600
qldsales@moffat.com.au

Western Australia
Telephone 08-9413 2400
wasales@moffat.com.au

Ice production per 24 hours

Ambient temperature / Water temperature

10°C / 10°C	21°C / 10°C	32°C / 21°C
75	74	60

Dimensions

Width: 680mm
Depth: 600mm
Height: 1009mm (including legs)
Nett weight: 67kg
Packed weight: 77kg

Water consumption

Air cooled version: 7.4 litres per hour

Electrical rating

Air cooled version: 230-240V, 1P+N+E, 50Hz, 670W,
10A cordset supplied

No. Circuit wire: 3
Compressor: 1400W
Energy consumption: 12.9kW/hr

Refrigerant type

R290

Installation distance from wall

Rear 100mm
Sides 150mm
Operating requirement air temperature 10-43°C

Water connection requirements

Inlet connection: R 3/4"
Cold water: 5-38°C
Pressure: 100-500kPa
Water outlet connection: Ø3/4"

Important Notice:

Models and specifications are subject to change without notice. This spec sheet is meant for commercial purpose only. For technical documentation please refer to our service manuals.



© Copyright Moffat Ltd
AU.SM.2001