

E603, E604

Electric Fish Fryers



E603



E604

- Powerful 17kW elements for better performance and faster recovery
- Variable thermostat
- Melt cycle switch
- Over-temperature reset button
- Full 1" drain valve
- Reinforced tank bash bar for longer tank life
- Heavy duty chrome plated legs with adjustable feet
- Heavy duty baskets and lids included
- Stainless basket hanger removable for cleaning
- Easy clean vitreous enamel control panel
- Elements swing clear for easy cleaning
- Easy clean stainless steel exterior
- Easy clean stainless steel tank

E603, E604 Electric Fish Fryers

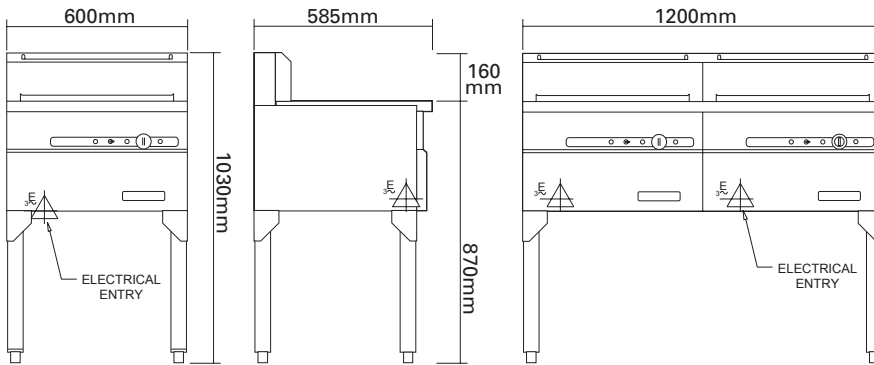

SINGLE TANK FRYER

DOUBLE TANK FRYER

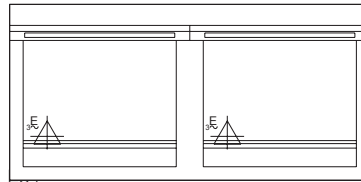
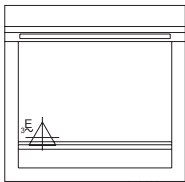

A strong stainless steel bar is welded into the front of the tanks on both the E603 and E604 strengthening the tank and extending its usable life. This gives the operator a convenient point to shake away excess oil from the fried food in the basket.

moffat.com.au
moffat.co.nz

Australia
moffat.com.au
Moffat Pty Limited
Victoria/Tasmania
740 Springvale Road
Mulgrave, Victoria 3170
Telephone +613-9518 3888
Facsimile +613-9518 3833
vsales@moffat.com.au

New South Wales
Telephone +612-8833 4111
nswsales@moffat.com.au

South Australia
Telephone +613-9518 3888
vsales@moffat.com.au

Queensland
Telephone +617-3630 8600
qldsales@moffat.com.au

Western Australia
Telephone +618-9413 2400
wasales@moffat.com.au

New Zealand
moffat.co.nz

Moffat Limited

Rolleston
45 Illinois Drive
Izone Business Hub
Rolleston 7675
Telephone +64 3-983 6600
Facsimile +64 3-983 6660
sales@moffat.co.nz

Auckland
Telephone +64 9-574 3150
sales@moffat.co.nz



ISO9001
Quality
Management
Standard

Designed and manufactured by



ISO9001
All Bakbar products are designed and manufactured by Moffat using the internationally recognised ISO9001 quality management system, covering design, manufacture and final inspection, ensuring consistent high quality at all times.

In line with policy to continually develop and improve its products, Moffat Limited reserves the right to change specifications and design without notice.

© Copyright Moffat Ltd
AN.BS.S.1.20

SPECIFICATIONS

Tank Size

Width	510mm
Front to back	348mm
Depth	315mm

Capacity

E603	30 litres
E604	30 litres per tank

Connection

400-415V, 3P+N+E

Total Connected Load Per Line

		LINE 1	LINE 2	LINE 3
E603	17kW	23.6A	23.6A	23.6A
E604	17kW(x2) or 34kW	23.6A(x2) 47.2A	23.6A(x2) 47.2A	23.6A(x2) 47.2A

Packing data

E603	89kg, 0.51m ³
E604	151kg, 0.97m ³

Construction

Stainless steel tank, sides and front
Chrome plated legs
Stainless steel lids
Chrome plated baskets