

# CW2H

## 1200mm 2 Hole Gas Waterless Woks

**CW2H-CC** 2 Hole, 2 Chimney Burners

**CW2H-CD** 2 Hole, 1 Chimney Burner, 1 Duckbill Burner

**CW2H-DD** 2 Hole, 2 Duckbill Burners



CW2H

- 800mm compact depth
- Cobra suite matching
- Waterless wok deck
- 14" wok hole
- Duckbill and Chimney burner model options
- 105 MJ/hr 18 jet Duckbill burners<sup>1</sup>
- 95 MJ/hr 24 jet Chimney burners
- High splashback with shelf
- Water folding laundry arm on splashback
- Rear waste channel
- Stainless steel spill tray
- Lift out wok ring
- Flame failure protection with pilot burner

Also Available



CW1H



CW3H

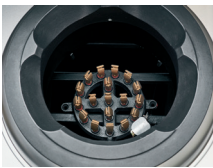

Duckbill burner



Chimney burner

### OVERALL CONSTRUCTION

- Full chassis construction
- Double skin insulated wok deck
- Stainless steel exterior finish
- Heavy-duty cast iron wok rings (removable)
- Stainless steel spill tray
- 63mm dia. stainless steel legs with adjustable feet

### CONTROLS

- Pilot On/Off control with flame failure valve
- Main burner On/Off valve with High-Low burner adjustment
- Quarter turn main burner control handles
- Quarter turn water valve handle

### CLEANING AND SERVICING

- Stainless steel exterior finish
- Lift out wok rings for full cleaning ability
- Slide out spill tray
- Rear waste channel with removable grate for debris collection
- Access to all parts from front and top for servicing

<sup>1</sup> NZ models Duckbill burner rating 105MJ/hr Natural Gas / 85MJ/hr on LP gas.

### Matching Products



CSP6

CN4

CT9

CP4

CS9 / C900-S

C6B

CR9D

CR6C

CF4

C9C

### CW2H

### 1200mm 2 Hole Gas Waterless Woks

**CW2H-CC** 2 Hole, 2 Chimney Burners

**CW2H-CD** 2 Hole, 1 Chimney Burner, 1 Duckbill Burner

**CW2H-DD** 2 Hole, 2 Duckbill Burners

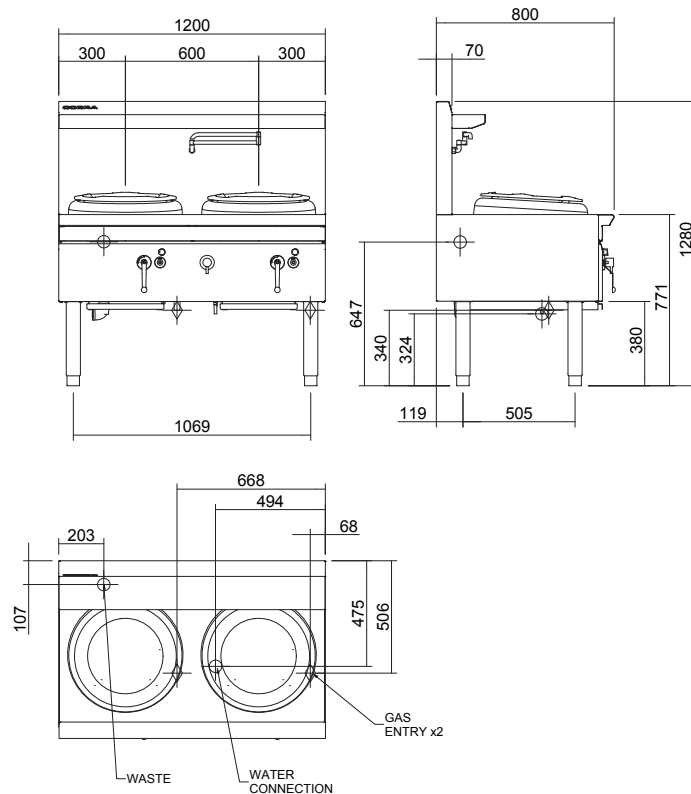

CW2H

#### SPECIFICATIONS

##### Burners

95MJ/hr 24 jet Chimney burner  
105MJ/hr 18 jet Duckbill burner  
(NZ - LP gas rating 85 MJ/hr)

##### Gas Rating - Total

CW2H-CC 190 MJ/hr  
CW2H-CD 200 MJ/hr  
(NZ- LP gas rating 180 MJ/hr)  
CW2H-DD 210 MJ/hr  
(NZ- LP gas rating 170 MJ/hr)

##### Wok size

14" wok ring  
Suits woks 40-60cm / 16-24"

##### Gas connection (x2)

Separate gas connection for each wok hole. R3/4 (BSP) male each wok hole 506mm from rear, 340mm from floor, 68mm and 668mm from RH side

All units supplied with Natural-LP gas regulators for each wok connection

Supplied gas regulators include Test Point for appliance operating pressure  
Supplied regulator(s) must be fitted to each appliance gas connection when installed

##### Water connection

Cold water connection  
1 x 1/2" O.D. copper tube  
475mm from rear, 325mm from floor 494mm from RH side

##### Drain connection

Connection to waste drain 1-1/4" BSP drain waste  
107mm from rear, 647mm from floor, 203mm from LH side

##### Dimensions

Width 1200mm  
Depth 800mm  
Height 771mm  
Incl. splashback 1280mm

Nett weight  
135kg

Packing data  
1.48m3, 211kg  
Width 1235mm  
Depth 865mm  
Height 1382mm

##### Gas types

Available in Natural gas and LP gas, please specify when ordering



Cert. No. AGA 8593G

moffat.com.au  
moffat.co.nz

Australia  
moffat.com.au

Moffat Pty Limited

Victoria/Tasmania  
740 Springvale Road  
Mulgrave, Victoria 3170  
Telephone +613-9518 3888  
Facsimile +613-9518 3833  
vsales@moffat.com.au

New South Wales  
Telephone +612-8833 4111  
nswsales@moffat.com.au

South Australia  
Telephone +613-9518 3888  
vsales@moffat.com.au

Queensland  
Telephone +617-3630 8600  
qldsales@moffat.com.au

Western Australia  
Telephone +618-9413 2400  
wasales@moffat.com.au

New Zealand  
moffat.co.nz

Moffat Limited

Rolleston  
45 Illinois Drive  
Izone Business Hub  
Rolleston 7675  
Telephone +64 3-983 6600  
Facsimile +64 3-983 6660  
sales@moffat.co.nz

Auckland  
Telephone +64 9-574 3150  
sales@moffat.co.nz



ISO9001  
Quality  
Management  
Standard

Designed and manufactured by



##### ISO9001

All Cobra products are designed and manufactured by Moffat using the internationally recognised ISO9001 quality management system, covering design, manufacture and final inspection, ensuring consistent high quality at all times.

In line with policy to continually develop and improve its products, Moffat Limited reserves the right to change specifications and design without notice.

© Copyright Moffat Ltd  
AN.C.01.19 / 1598