



Independent MKN combi steamer FlexiCombi stacked 2x 12 tray GN 1/1 with MagicPilot operation system.

Product Advantages:

- MagicPilot – Robust, wear-free, capacitive true colour touch screen.
- Video assist – Interactive user assistance with clips featuring professional chefs.
- CombiDoctor – Self-diagnosis programme.
- GreenInside – Indicates the energy and water consumption for each cooking programme.
- AutoChef – Up to 350 individual cooking programmes and manual operating system.
- Durable hygienic cooking chamber and chamber door with insulated triple glazing.
- DynaSteam2 – It speeds up the cooking process and saves energy.
- Integrated heat exchanger.
- WaveClean – Automatic cleaning system (safe, easy, economical).
- USB interface.
- 3 years warranty parts and labour.

Installation requirements:

- Soft Water / Water supply / Connection to waste water provided by customer.
- If mineral content is high, reverse osmosis system may be advisable.

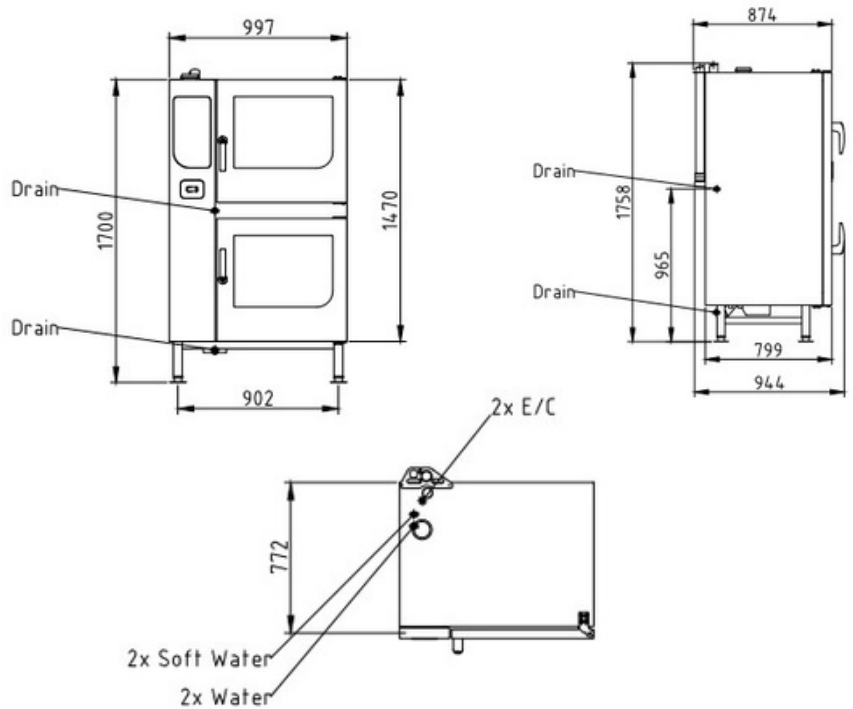

Technical Data:

Width x Height x Depth (mm)	997 x 1700 x 799
Connected load (electrical) (kW):	2x 20.9
Voltage (V) / EC:	each 415 3 phase AC
Recommended fuses (A):	each 3 x 32
Frequency range (Hz):	each 50
Soft Water connection:	2x DN 20 (R ¾" inside)
Water connection:	2x DN 20 (R ¾" inside)
Waterpressure (kPa):	200 - 600 (2 - 6 bar)
Drain connection:	2x DN 50
Gastronorm 1/1 (530 x 325 mm):	2x 12 (max. 65 mm deep)
Gastronorm 2/1 (530 x 650 mm):	2x 6 (max. 65 mm deep)
Plates Ø 28 cm	each 24
Plates Ø 32 cm – plate trolley :	each 22
Material housing:	1.4301
Material cooking chamber:	1.4404
Gross weight (kg):	320
Heat emission latent (W):	each 3670 (7340)
Heat emission sensitive (W):	each 2450 (4900)
Type of protection:	IPX 5

