

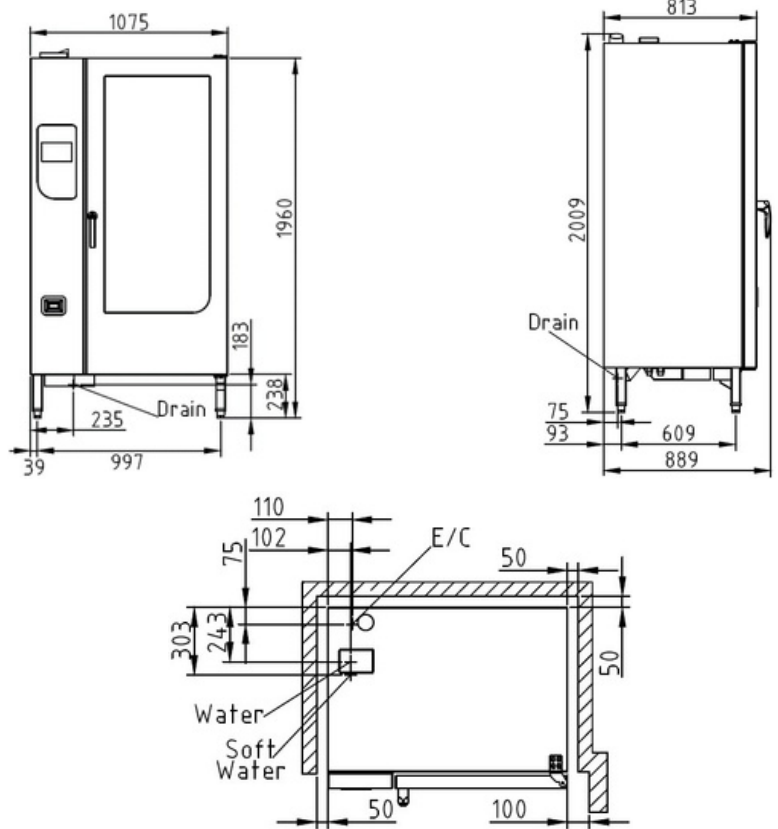

MKN combi steamer FlexiCombi 20 tray GN 1/1 or 20 FlexiRack® (530 x 570 mm) with MagicPilot operation system.

### Product Advantages:

- MagicPilot – Robust, wear-free, capacitive true colour touch screen.
- FlexiRack® – 50% more cooking capacity (= save time and energy).
- Video assist – Interactive user assistance with clips featuring professional chefs.
- CombiDoctor – Self-diagnosis programme.
- GreenInside – Indicates the energy and water consumption for each cooking programme.
- AutoChef – Up to 350 individual cooking programmes and manual operating system.
- EasyIn roll-in system for transport trolley racks to compensate for any unevenness of the floor up to 10 mm.
- Durable hygienic cooking chamber and chamber door with insulated triple glazing.
- DynaSteam2 – It speeds up the cooking process and saves energy.
- Integrated heat exchanger.
- WaveClean – Automatic cleaning system (safe, easy, economical).
- USB interface.
- 3 years warranty parts and labour.



Capacity: Meals per day	150 - 300 (GN 1/1)
	150 - 400 (FlexiRack)

### Installation requirements:

- Soft Water / Water supply / Connection to waste water provided by customer.
- If mineral content is high, reverse osmosis system may be advisable.



### Technical Data:

Width x Height x Depth (mm)	1075 x 1960 x 813
Connected load (electrical) (kW):	31.7
Voltage (V) / EC:	415 3 phase AC
Recommended fuses (A):	3 x 50
Frequency range (Hz):	50
Soft Water connection:	DN 20 (R ¾" inside)
Water connection:	DN 20 (R ¾" inside)
Waterpressure (kPa):	200 - 600 (2 - 6 bar)
Drain connection:	DN 50
FlexiRack® (530 x 570 mm)	20 (max. 65 mm deep)
Gastronorm 1/1 (530 x 325 mm):	20 (max. 65 mm deep)
Plates Ø 28 cm on FlexiRack® grids:	80
Plates Ø 32 cm – plate trolley :	80
Material housing:	1.4301
Material cooking chamber:	1.4404
Gross weight (kg):	375
Heat emission latent (W):	5706
Heat emission sensitive (W):	3804
Type of protection:	IPX 5

