

Product Advantages:

- Hob with 4 heating zones 3.0 kW each, oven 4.55 kW.
- Housing made completely of stainless steel.
- Tightly welded top plate with lateral drain channels for easy cleaning.
- Hob 715 x 555 mm, 18 mm thick.
- Hob made of heat resistant stainless steel or alternatively chrome plated with antireflection coating.
- Highly efficient contact heating elements.
- Easy to clean hob due to corner radii.

Installation requirements:

- Electrical supply provided by customer.

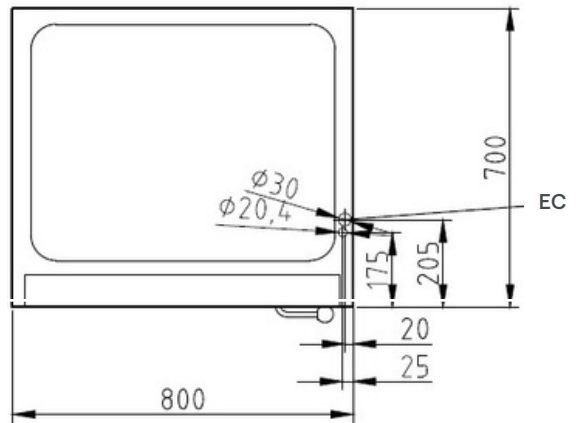
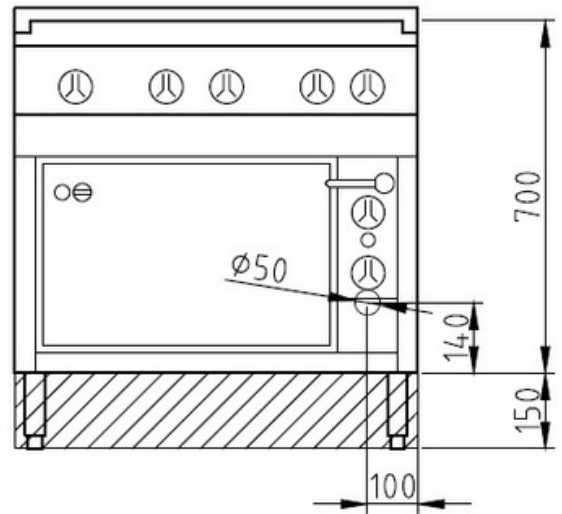

Technical Data:

Width x Height x Depth (mm)	800 x 700 (900) x 700
Effective area	4
Dim.: effect. Area (mm)	715 x 555
Connected load (elect.) (kW):	16.55
Voltage (V) / EC:	415 3 phase AC
Recommended fuses (A):	3 x 32
Net weight (kg):	150
Gross weight (kg):	159
Heat emission latent (W):	1688
Heat emission sensitive (W):	3992
Type of protection:	IPX5

