



Product Advantages:

- Basin 305 x 510 for 1x1/1 GN containers up to 200 mm deep.
- A multifunctional appliance for cooking and keeping warm.
- Housing made completely of stainless steel.
- Tightly welded top plate with lateral drain channels for easy cleaning.
- Basin made of corrosion resistant stainless steel.
- Very easy to clean because of indirect heating.
- SUPRA heating system-contact heating elements integrated into aluminium blocks ensure greater heating capacity and even distribution of heat, with short heating up times and a longer service life.
- Variable power adjustment and thermostatic temperature regulation.
- Equipped for connection to a power optimization system with potential free contact.

Installation requirements:

- Electrical supply provided by customer.

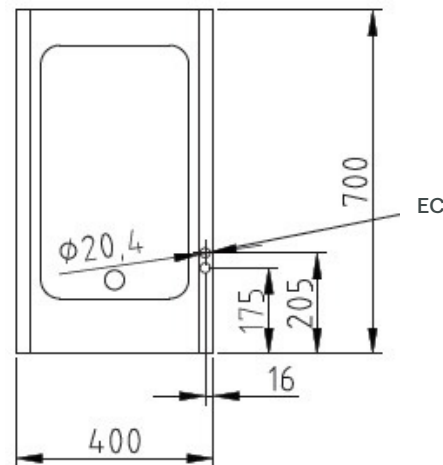
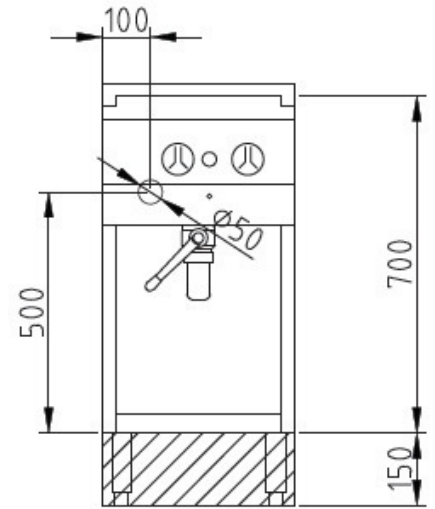

Technical Data:

Width x Height x Depth (mm)	400 x 700 (900) x 700
Effective area	1
Dim.: effect. Area (mm)	305 x 200 x 510
Connected load (elect.) (kW):	7.2
Voltage (V) / EC:	415 3 phase AC
Recommended fuses (A):	3 x 16
Net weight (kg):	46
Gross weight (kg):	51
Heat emission latent (W):	1440
Heat emission sensitive (W):	900
Type of protection:	IPX5

