



INDUSTRY KITCHENS

www.industrykitchens.com.au 1800 611 058

Product Advantages:

- Multifunctional unit for frying, cooking, steaming and stewing.
- 37 litres capacity.
- Housing made completely of stainless steel.
- Tightly welded top plate with lateral drain channels for easy cleaning.
- SUPRA heating system for greater heating capacity and even heat distribution
- Shorter heating up times and a longer service life of heating elements.
- Appliance with two separate heating zones.
- Frying pan made completely of stainless steel.
- Smoothly polished frying surface made of PowerBlock special sandwich material.
- Frying surface 700 x 540, 100 mm deep.
- Supplied ready for connection to a power optimising system.

Installation requirements:

- Electrical supply provided by customer.

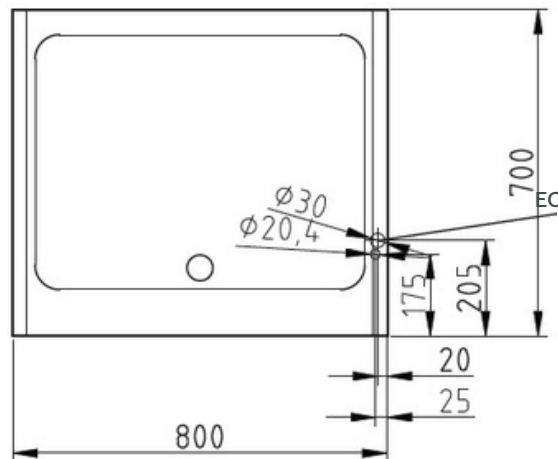
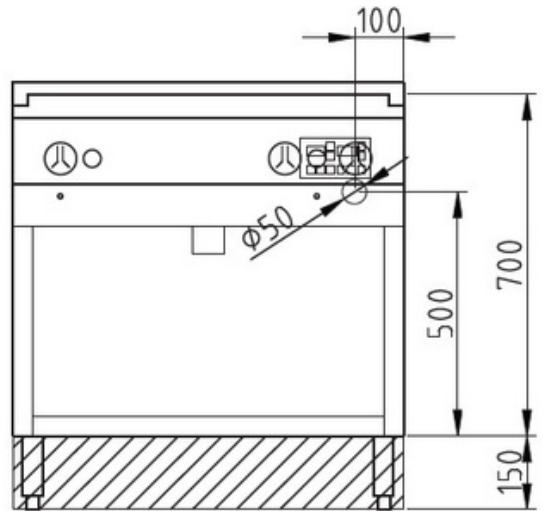

Technical Data:

Width x Height x Depth (mm)	800 x 700 (900) x 700
Effective area	1
Dim.: effect. Area (mm)	700 x 100 x 540
Nominal capacity (L):	37
Connected load (elect.) (kW):	10.8
Voltage (V) / EC:	415 3 phase AC
Recommended fuses (A):	3 x 20
Net weight (kg):	85
Gross weight (kg):	94
Heat emission latent (W):	4320
Heat emission sensitive (W):	4860
Type of protection:	IPX5

