



INDUSTRY KITCHENS

www.industrykitchens.com.au 1800 611 058

Product Advantages:

- Multifunctional unit for frying, cooking, steaming and stewing.
- 26 litres capacity.
- Housing made completely of stainless steel.
- Tightly welded top plate with lateral drain channels for easy cleaning.
- SUPRA heating system for greater heating capacity and even heat distribution
- Shorter heating up times and a longer service life of heating elements.
- Two separate heating zones.
- Frying pan made completely of stainless steel.
- Smoothly polished surface made of PowerBlock material.

Installation requirements:

- Electrical supply provided by customer.

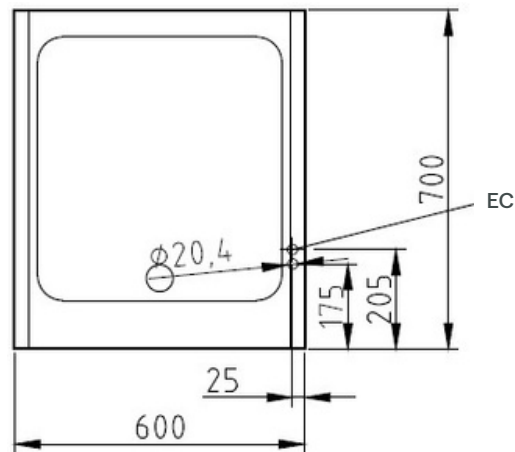
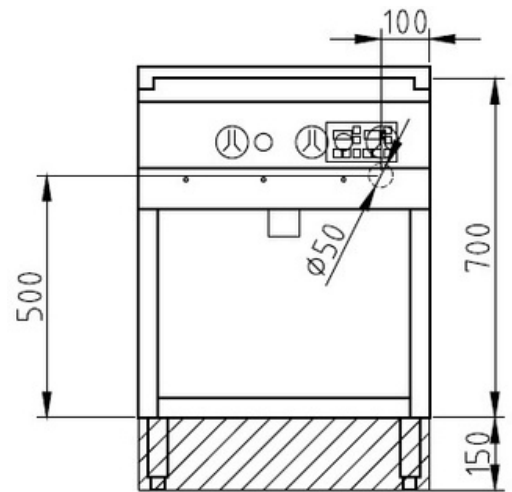

Technical Data:

Width x Height x Depth (mm)	600 x 700 (900) x 700
Effective area	1
Dim.: effect. Area (mm)	500 x 100 x 540
Nominal capacity (L):	26
Connected load (elect.) (kW):	7.2
Voltage (V) / EC:	415 3 phase AC
Recommended fuses (A):	3 x 16
Net weight (kg):	65
Gross weight (kg):	72
Heat emission latent (W):	2880
Heat emission sensitive (W):	3240
Type of protection:	IPX5

