

### Product Advantages:

- Cast iron grids.
- Grill surface 380 x 420 mm with separate grid halves.
- Housing made completely of stainless steel.
- Tightly welded top plate with lateral drain channels for easy cleaning.
- Heating elements can be raised completely out of vat for easy cleaning.
- Two separate heating zones.
- Fat collection tray can be filled with water for easier cleaning.

### Installation requirements:

- Electrical supply provided by customer.

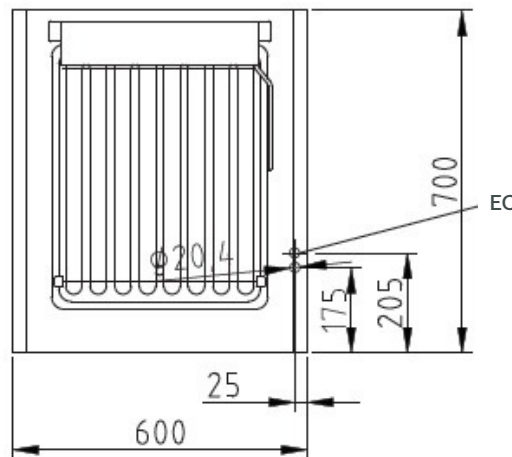
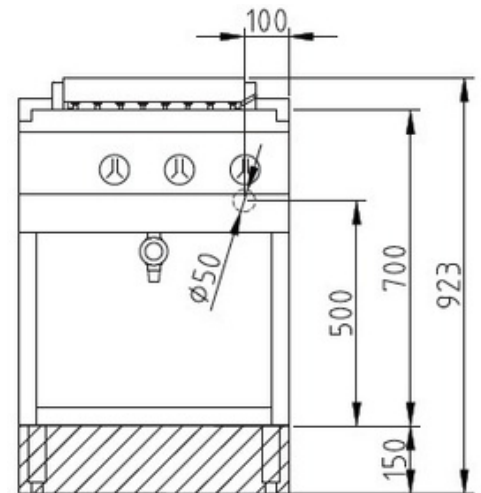

### Technical Data:

Width x Height x Depth (mm)	600 x 700 (900) x 700
Effective area	1
Dim.: effect. Area (mm)	380 x 420
Connected load (elec.) (kW):	7.0
Voltage (V) / EC:	415 3 phase AC
Recommended fuses (A):	3 x 20
Net weight (kg):	40
Gross weight (kg):	47
Heat emission latent (W):	1225
Heat emission sensitive (W):	4900
Type of protection:	IPX5

