



For boiling, steaming, frying, braising, simmering as well as pressureless cooking and pressure cooking for shorter cooking times. For cooking meat, quick-fried meat, egg products, fish, milk products and side dishes.

### Product Advantages:

- Housing made completely of stainless steel.
- Pan made of heat resistant steel as standard.
- SUPRA heating system-contact heating elements integrated into aluminium blocks ensure greater heating capacity and even distribution of heat, with short heating up times and longer service life.
- Appliance with two separately adjustable heating zones.
- Ideal pan positioning prevents spills and guarantees that the pan is fully emptied. Equipped for connection to a power optimization system.

### Installation requirements:

- Electrical supply provided by customer.

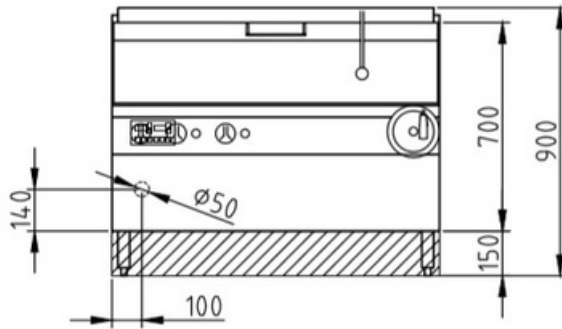
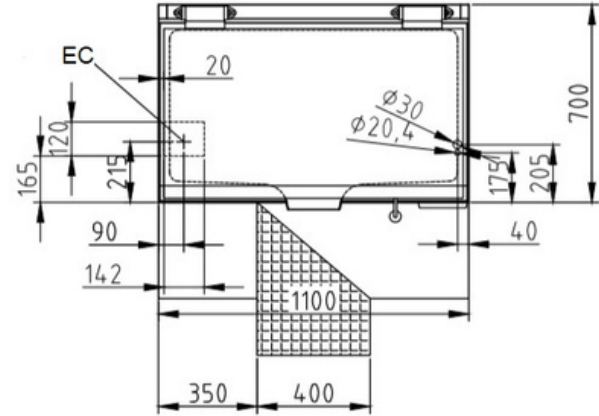

### Technical Data:

Width x Height x Depth (mm)	1100 x 700 x 700
Effective area	1
Dim.: effect. Area (mm)	1020 x 190 x 535
Nominal capacity (L):	85
Nominal fill quantity (L):	63
Connected load (elect.) (kW):	14.4
Voltage (V) / EC:	415 3 phase AC
Recommended fuses (A):	3 x 32
Frequency range (Hz):	50
Standard gas pressure (mbar)	20
Natural gas	
Standard gas pressure (mbar)	30 (DE), 50 (EU)
Liquid gas	
Net weight (kg):	175
Gross weight (kg):	208
Heat emission latent (W):	5760
Heat emission sensitive (W):	6480
Type of protection:	IPX5

