

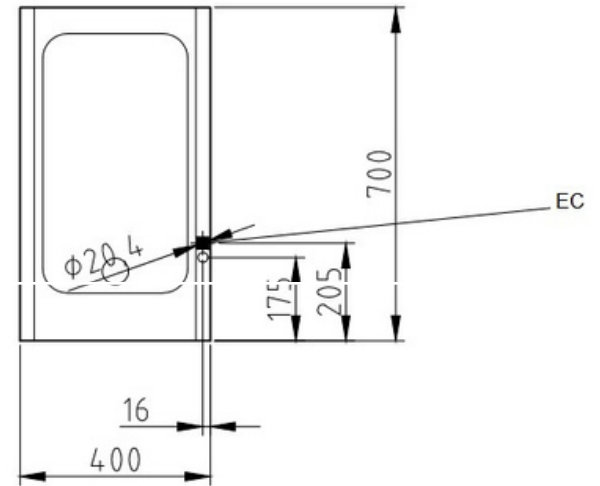

Product Advantages:

- Housing made completely of stainless steel.
- Tightly welded top plate with lateral drain channels for easy cleaning.
- SUPRA heating system-contact heating elements integrated into aluminium blocks ensure greater heating capacity and even heat distribution, shorter heating up times and a longer service life of heating elements.
- Appliance with two separate heating zones.
- Steel frying surface 305 x 540 mm.
- Chrome nickel steel half ribbed.
- Fat collecting container approx. 4 litres.
- Supplied ready for connection to a power optimising system.

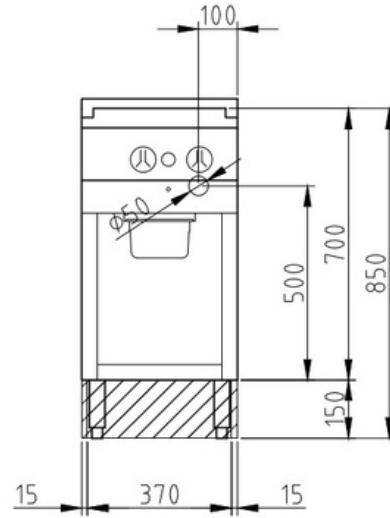

Installation requirements:

- Electrical supply provided by customer.



Technical Data:

Width x Height x Depth (mm)	400 x 700 x 700
Effective area	1
Dim.: effect. Area (mm)	305 x 540
Connected load (elect.) (kW):	5.4
Voltage (V) / EC:	415 3 phase AC
Recommended fuses (A):	3 x 20
Net weight (kg):	50
Gross weight (kg):	55
Heat emission latent (W):	2160
Heat emission sensitive (W):	1782
Type of protection:	IPX5

