

Product Advantages:

- Housing made completely of stainless steel.
- Tightly welded top plate with lateral drain channels for easy cleaning.
- SUPRA heating system for greater heating capacity and even heat distribution, shorter heating up times and a longer service life of heating elements.
- Smoothly polished frying surface made of PowerBlock special sandwich material.
- Appliance with two separate heating zones.
- Steel frying surface 500 x 540 mm.
- Fat collecting container approx. 4 litres.
- Supplied ready for connection to a power optimising system.

Installation requirements:

- Electrical supply provided by customer.

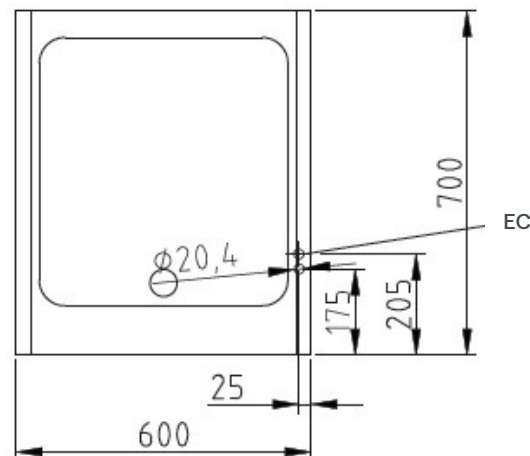
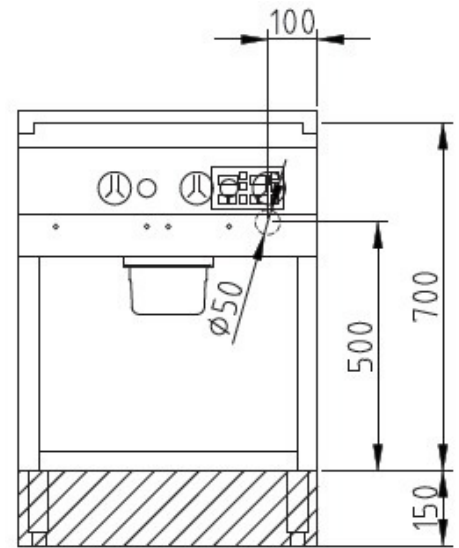

Technical Data:

Width x Height x Depth (mm)	600 x 700 (900) x 700
Effective area	1
Dim.: effect. Area (mm)	500 x 540
Connected load (elect.) (kW):	7.2
Voltage (V) / EC:	415 3 phase AC
Recommended fuses (A):	3 x 16
Net weight (kg):	70
Gross weight (kg):	77
Heat emission latent (W):	2880
Heat emission sensitive (W):	2376
Type of protection:	IPX5

