



### INDUSTRY KITCHENS

www.industrykitchens.com.au 1800 611 058

#### Product Advantages:

- Basin 305 x 510 for 1x1/1 gastro norm containers up to 200 mm deep.
- Housing made completely of stainless steel.
- Visible surfaces with polished and satin finish, 320 grit.
- Tightly welded top plate with lateral drain channels for easy cleaning.
- Very easy to clean because of indirect heating by tubular heating elements, with thermostatic temperature control.
- Integrated appliance switch, control lamp and dry run protection.

#### Installation requirements:

- Electrical supply provided by customer.

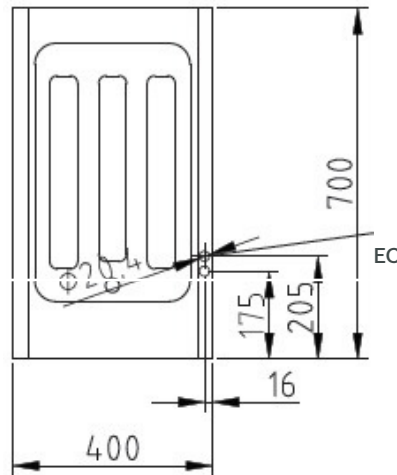
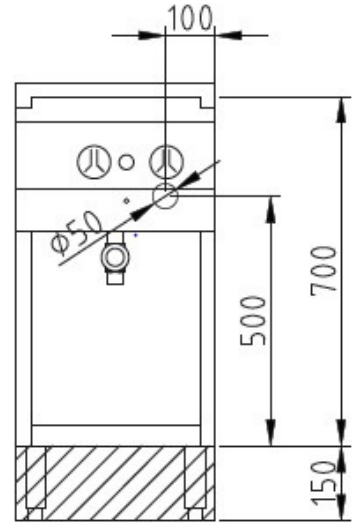

#### Technical Data:

Width x Height x Depth (mm)	400 x 700 (900) x 700
Effective area	1
Dim.: effect. Area (mm)	305 x 200 x 510
Connected load (elect.) (kW):	2.0
Voltage (V) / EC:	240 1 phase AC
Recommended fuses (A):	1 x 16
Net weight (kg):	34
Gross weight (kg):	39
Heat emission latent (W):	400
Heat emission sensitive (W):	250
Type of protection:	IPX5

