



Product Advantages:

- Protection against overheating by automatic power resetting.
- Energy saving, electronic saucepan recognition system which can be switched to manual operation.
- Housing made completely of stainless steel.
- Infinitely variable temperature control for each cooking zone.
- Appliance feet which are adjustable in height.
- Easy to clean.
- Body is buckling resistant, self-supporting, closed construction with side walls, rear wall and bottom.

Installation requirements:

- Electrical power provided by customer.

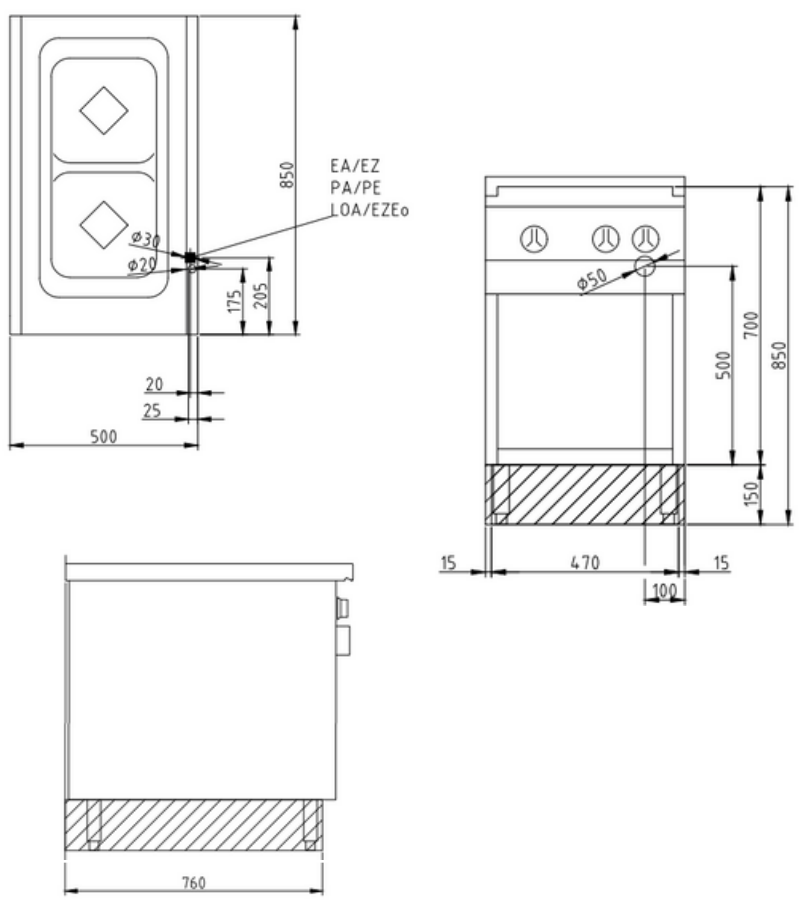

Technical Data:

Width x Height x Depth (mm)	500 x 700 x 850
Effective area	1
Dim.: effect. Area (mm)	340 x 690
Connected load (elect.) (kW):	8
Voltage (V) / EC:	415 3 phase AC
Recommended fuses (A):	3 x 32
Frequency Range (Hz):	50
Net Weight (kg):	58
Gross Weight (kg):	67
Heat emission latent (W):	640
Heat emission sensitive (W):	1600
Type of protection:	IPX5

