

Product Advantages:

- Housing made completely of stainless steel.
- Visible surfaces with polished and satin finish, 320 grit.
- Buckling resistant, self-supporting, closed construction with side walls, rear wall and bottom.
- Tightly welded top plate with lateral drain channels for easy cleaning.
- Heating by ceramic radiant heating elements, activated via the appliance switch.

Installation requirements:

- Electrical supply provided by customer.

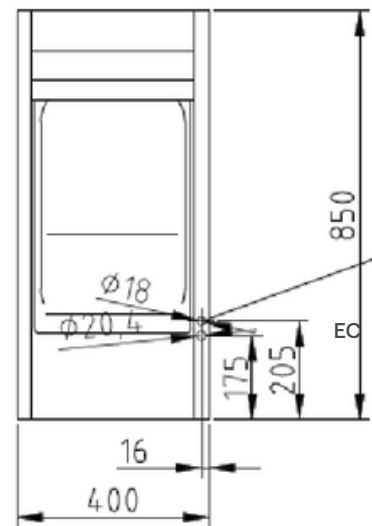
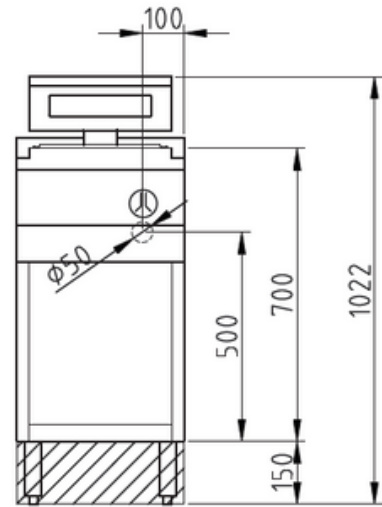

Technical Data:

Width x Height x Depth (mm)	400 x 700 (900) x 850
Effective area	1
Dim.: effect. Area (mm)	325 x 200 x 530
Connected load (elect.) (kW):	1
Voltage (V) / EC:	240 1 phase AC
Recommended fuses (A):	1 x 16
Net weight (kg):	48
Gross weight (kg):	55
Heat emission latent (W):	175
Heat emission sensitive (W):	700
Type of protection:	IPX5

