

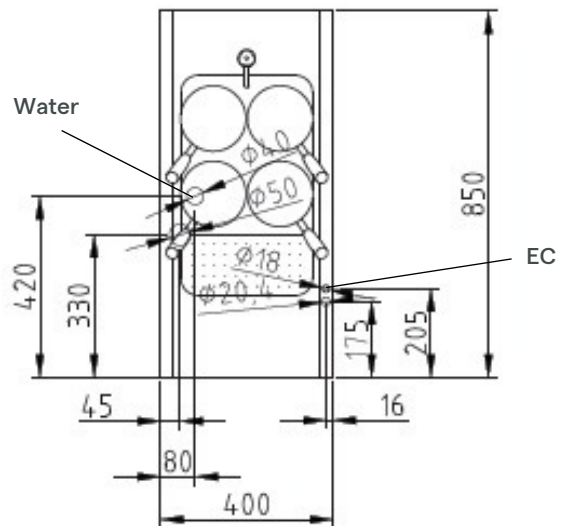

Product Advantages:

- Basin 305 x 510 x 210 mm deep.
- Housing made completely of stainless steel U-shaped connection channel, flush with top plate; tightly fitted to the substructure, for maximum hygiene.
- Directed drainage of fluids via a drip outlet in the top plate at the front.
- Basin made of corrosion resistant stainless steel.
- Very easy to clean because of indirect heating.
- SUPRA heating system – contact heating elements integrated into aluminium blocks ensure greater heating capacity and even distribution of heat, with short heating up times and a longer service life for the heating elements.
- Variable power adjustment and thermostatic temperature regulation.
- Swivelling water inlet tap DN 15 behind the basin.
- Standpipe with starch collection plate and perforated cover.
- Stainless steel baskets (Diam. 150 mm).
- Prepared for connection to a power optimizing system.

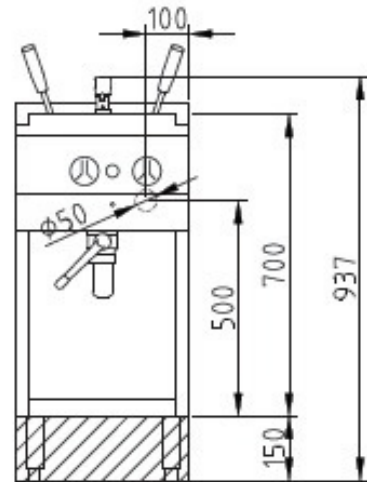

Installation requirements:

- Electrical supply provided by customer.
- Connection to the water supply mains provided by the customer.



Technical Data:

Width x Height x Depth (mm)	400 x 700 (900) x 850
Effective area	1
Dim.: effect. Area (mm)	305 x 210 x 510
Connected load (elect.) (kW):	7.2
Voltage (V) / EC:	415 3 phase AC
Recommended fuses (A):	3 x 16
Net weight (kg):	55
Gross weight (kg):	62
Heat emission latent (W):	1440
Heat emission sensitive (W):	900
Type of protection:	IPX5

