

Product Advantages:

- Max 12.5 L. Surface load of heating elements 3.7 W/cm².
- Housing made completely of stainless steel.
- Tightly welded top plate with lateral drain channels for easy cleaning.
- Easy to clean because the heating elements can be raised out of the basin completely.
- Deeper, cool zone under the heating elements collect all loose particles e.g. breadcrumbs.
- Frying basin 180 x 400 x 235 mm deep.
- Connection to a power optimising system.

Installation requirements:

- Electrical supply provided by customer.

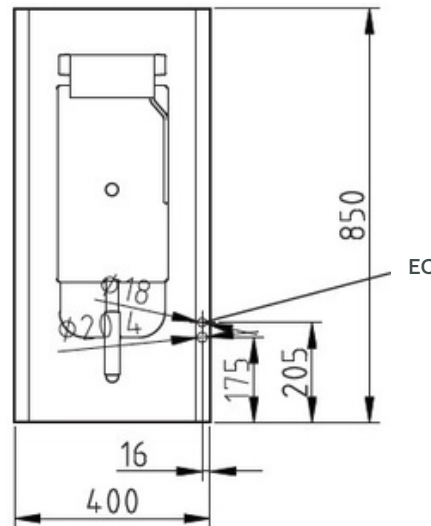
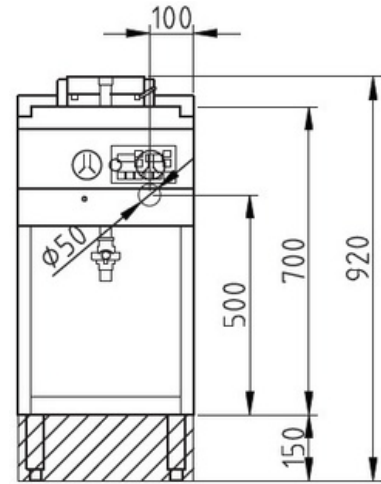

Technical Data:

Width x Height x Depth (mm)	400 x 700 (900) x 850
Effective area	1
Dim.: effect. Area (mm)	180 x 235 x 400
Nominal capacity (L):	12.5
Connected load (elect.) (kW):	10
Voltage (V) / EC:	415 3 phase AC
Recommended fuses (A):	3 x 20
Net weight (kg):	31
Gross weight (kg):	38
Heat emission latent (W):	7000
Heat emission sensitive (W):	900
Type of protection:	IPX5

