



INDUSTRY KITCHENS

www.industrykitchens.com.au 1800 611 058

Product Advantages:

- Heating power infinitely variable for each cooking zone.
- Completely electrically wired inside.
- Sealing by means of patented connecting method.
- Easy to clean.
- Heating by high output induction generators for fast energy transmission.
- Saves energy due to high efficiency.
- Equipped for installation of a 580 mm high Counter SL lower section with removable appliance feet which are adjustable in height.

Installation requirements:

- Electrical power provided by customer.

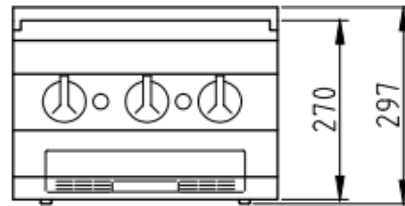
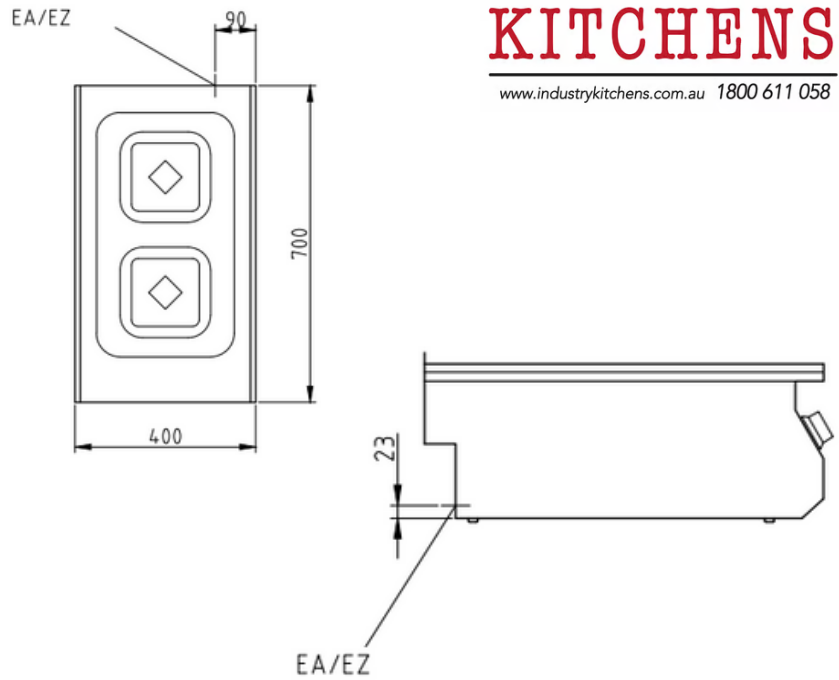

Technical Data:

Width x Height x Depth (mm)	400 x 270 x 700 mm
Effective area	1
Dim.: effect. Area (mm)	305 x 540
Connected load (elect.) (kW):	7.0
Voltage (V) / EC:	415 3 phase
Recommended fuses (A):	3 x 32
Gross weight (kg):	48
Heat emission latent (W):	560
Heat emission sensitive (W):	490
Type of protection:	IPX5

