

For boiling, steaming, frying, braising, simmering. For cooking meat, quick-fried meat, egg products, fish, milk products and side dishes.

Product Advantages:

- Housing made completely of stainless steel.
- Tightly welded top plate with lateral drain channels for easy cleaning.
- Pan made of heat resistant steel as standard.
- SUPRA heating system-contact heating elements integrated into aluminium blocks ensure greater heating capacity and even distribution of heat, with short heating up times and longer service life.
- Appliance with two separately adjustable heating zones.
- 65 mm gap between pan and side columns, for easy cleaning.
- Pan made of heat resistant steel as standard.
- Equipped for connection to a power optimization system with potential free contact as standard.
- Double walled hinged lid.
- Including mixing faucet

Installation requirements:

- Electrical supply provided by customer.

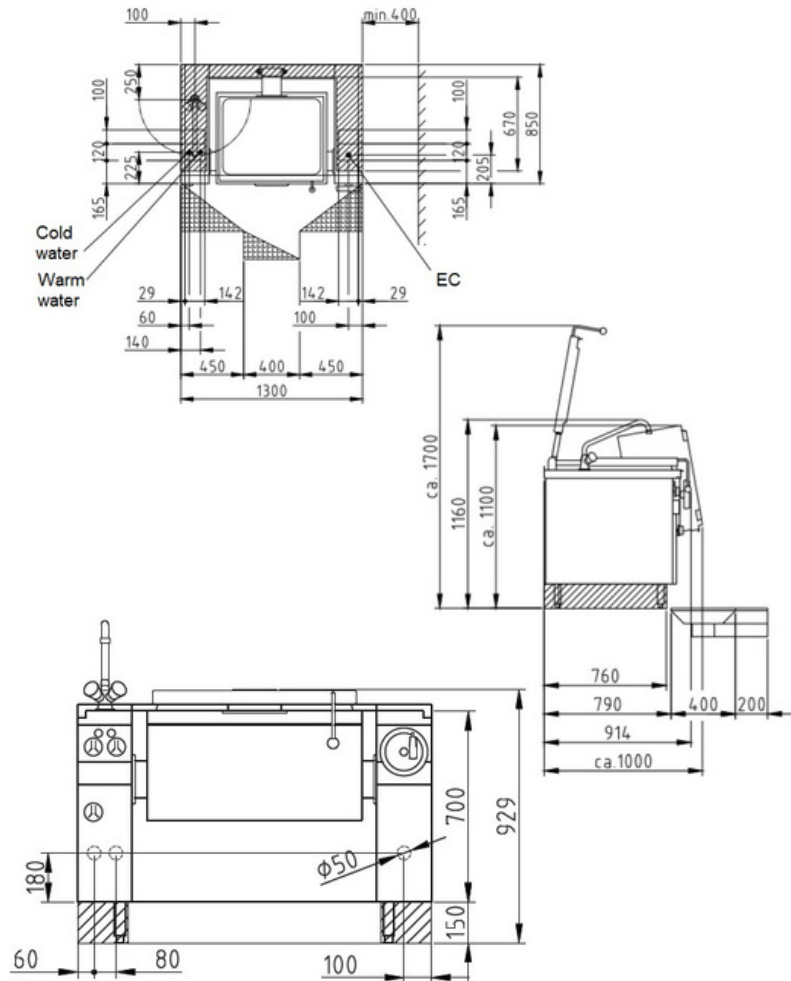

Technical Data:

Width x Height x Depth (mm)	1300 x 700 x 850
Effective area	1
Dim.: effect. Area (mm)	700 x 210 x 540
Nominal capacity (L):	80
Nominal fill quantity (L):	65
Connected load (elect.) (kW):	10.8
Voltage (V) / EC:	415 3 phase AC
Recommended fuses (A):	3 x 20
Frequency range (Hz):	50
Net weight (kg):	222
Gross weight (kg):	262
Heat emission latent (W):	4320
Heat emission sensitive (W):	4860
Type of protection:	IPX5

