



# INDUSTRY KITCHENS

www.industrykitchens.com.au 1800 611 058

### Product Advantages:

- Griddle pan 100 mm deep with griddle plate with large radii which are easy to clean.
- Completely wired internally.
- Temperature control by precision thermostats.
- Griddle plate, finely ground, with PowerBlock sandwich frying plate bottom.
- Housing made completely of stainless steel.
- Control panel with profile to protect the control elements, can be taken off at the front for simple and cost-efficient service access.
- Adjustable heating zone.
- Closable fat drain outlet at the front.

### Installation requirements:

- Electrical supply provided by customer.

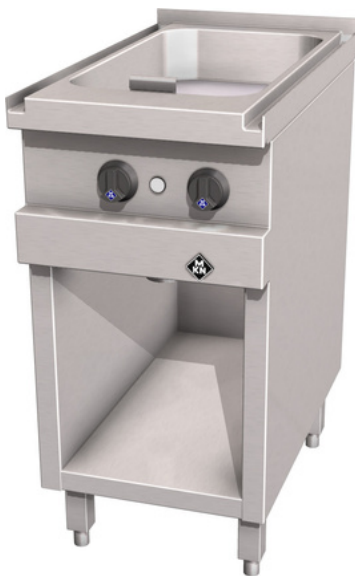
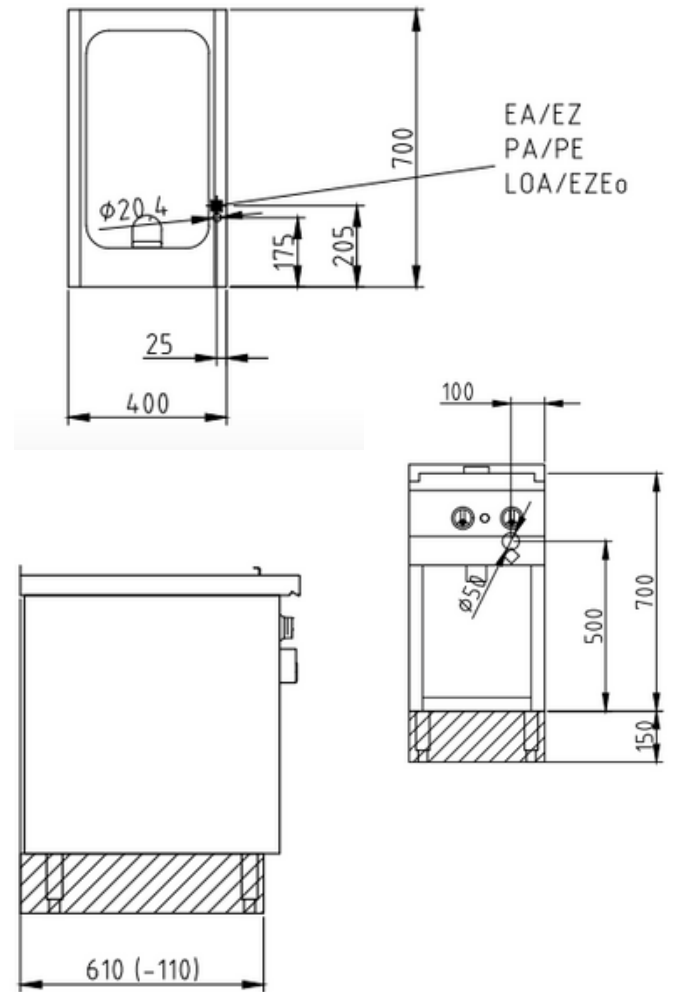

### Technical Data:

Width x Height x Depth (mm)	400 x 700 x 700
Effective area	1
Dim.: effect. Area (mm)	300 x 540 x 100
Connected load (elect.) (kW):	5.4
Voltage (V) / EC:	415 3 phase AC
Recommended fuses (A):	3 x 20
Frequency Range (Hz):	50/60
Nominal Capacity (L):	15
Heat emission latent (W):	2160
Heat emission sensitive (W):	1782
Type of protection:	IPX5

