

More than Fresh.

MF 100.2

The condensing unit is remote

**Organize your production
and processes with flexibility
24 hours a day.**



YIELD PER CYCLE

from +90°C to +3°C	100 kg
from +90°C to -18°C	100 kg

CAPACITY

Trolleys n.	1x20 (GN 2/1 or 600x800 mm)
Trolleys n.	2x20 (GN 1/1 or 600x400 mm)

DIMENSIONS

width	1600 mm
depth	1425 mm
height	2350 mm
weight	480 kg

ELECTRICAL DATA STANDARD VERSION

max absorbed power	2,4 kW
max absorbed current	5,5 A
voltage	400 V-50Hz (3N+PE)

ELECTRICAL DATA PLUS VERSION

max absorbed power	10,4 kW
max absorbed current	15,3 A
voltage	400 V-50Hz (3N+PE)

CONDENSING UNIT UC100

max absorbed power	7 kW
max absorbed current	15,8 A
voltage	400 V-50Hz (3N+PE)
width	872 mm
depth	1351 mm
height	1418 mm
weight	200 kg

MYA, TOUCH SCREEN INTERFACE

MultiFresh® comes with *MyA*, a **touch screen interface with 7"** screen which makes using the machine simple, even for inexperienced operators. The **intuitive icons** give access to the **numerous functions** provided by MultiFresh® for optimum control of all the production processes.

MyA is used to **customize all the parameters for each cycle** – ventilation, time, temperature, etc. – to create the ideal process for each item.

BLAST CHILLING AND SHOCK FREEZING CYCLES

MultiFresh® chills to +3°C and freezes to -18°C **from any temperature, including boiling hot products**, maintaining the consistency, moisture and nutrients of each type of food. MultiFresh® rapidly goes through the temperature range of **+90°C to +70°C, fundamental for quality**, and **+40°C to +10°C, to limit bacterial proliferation**. It freezes to **-18°C**, guaranteeing the **formation of micro-crystals** that do not spoil the structure of the food.

THAWING/REGENERATING CYCLES (PLUS version only)

MultiFresh® allows you to **choose the temperature, time and thickness** at which the food should be thawed and ready for use, by means of **controlled ventilation** in the chamber. Controlling the thawing process and setting the right temperature slows down bacterial proliferation and **keeps the structure of food intact**.

PROOFING CYCLES (PLUS version only)

MultiFresh® provides **cycles for natural proofing** that maintains the product's moisture, without sudden changes in temperature. *MyA* is used to plan the time at which to have perfectly proofed products and parameters are easily set to create the ideal environment for proofing. At the end of the cycle **products can be proofed and blast chilled or shock frozen**, as required.

LOW TEMPERATURE COOKING CYCLES (PLUS version only)

MultiFresh® **cooks meat or fish at low temperature, going automatically on to blast chilling or shock freezing** immediately after cooking. The main advantages of this method are exalted flavour and more uniform cooking. For ice cream makers and confectioners MultiFresh® provides **cooking cycles for meringues or fruit in syrup** used to make bases for single portions, semifreddos and dacquoise in-house, and better manage production costs.

REGENERATION CYCLES (PLUS version only)

MultiFresh® is used to regenerate dishes by setting the temperature and time at which the product must be hot, **ready to serve, going automatically from +3°C or -18°C to regeneration** to the required temperature, without spoiling it.

HOLDING CYCLES (catering and ice cream makers only) (PLUS version only)

MultiFresh® keeps food intact **at the required temperature, positive or negative**, according to needs.

CHOCOLATE CYCLES (confectioners and ice cream makers) (PLUS version only)

MultiFresh® comes with **cycles dedicated to chocolate**, which keep it at the **right level of moisture and temperature for perfect preservation over a long period**. MultiFresh® **melts and holds several types of chocolate**, reducing waiting time. It **partially freezes (at -7°C)** pralines and chocolate decorations and gives a velvety finish to chocolate figures. It rapidly **chills chocolate in moulds** so that it is quickly available and moisture does not form on the product.

PASTEURIZATION (PLUS version only)

MultiFresh® **pasteurizes and blast chills (+3°C) or pasteurizes and shock freezes (-18°C)** so that products can be held longer.

MAXIMUM FLEXIBILITY

MultiFresh® is easily set up for all food business areas – *Catering, Confectioners, Ice Cream Makers and Bakers* – with a choice of numerous functions for each sector – *Chilling, Freezing, Thawing, Reconstitution, Proofing, Low Temperature Cooking, Chocolate, Holding, Regeneration and Pasteurization*.

IRINOX BALANCE SYSTEM®:

The principle on which blast chillers operate consists of removing heat from food in the shortest time possible in order to limit product ageing. Our blast chillers guarantee **the fastest heat removal, also with boiling hot food**, due to the Irinox Balance System®, i.e. **the perfect size of the main refrigerator components** (condenser, evaporator, compressor and fan).

▪ Condenser

Condensers are built to the drawings and specifications of

UNIQUE SELLING POINTS



Irinox R&D and have **large exchange surfaces** to guarantee **high performance even with high ambient temperatures**. They are built to reduce acoustic impact and the amount of refrigerant involved.

▪ Evaporator

Built to the drawings and specifications of Irinox R&D with **large heat exchange surfaces** to prevent food dehydration. A Multi-injection system ensures good performance and **cataphoresis** anti-corrosion treatment prolongs the life of the evaporator.

▪ Compressor

The compressors selected by Irinox guarantee **low energy consumption and great reliability** and meet their stated productivity.

▪ Ventilators

The new generation **variable speed fans** with innovative design and materials are **exclusive to Irinox**. They provide **uniform ventilation and controlled humidity** throughout the chamber. The system that stops the fan immediately when the door is opened avoids loss of cold with the door open.

SANIGEN®: SANIFICATION 24/7

The Irinox patented sanitization system **sanitizes every part of the chamber**, including the **areas difficult to access for cleaning** (e.g. the evaporator).

The system's efficiency, tested by Udine University and **certified by the Italian Ministry of Health**, guarantees **bacteria abatement of 99.5%**. *Sanigen®* also acts to **eliminate unpleasant odours** that can occur at the end of the work cycle or the working day.

MULTISENSOR®

MultiFresh® comes with a *MultiSensor®* **5-point probe** for perfect temperature control. **Core temperature readings** provide *MyA* software with extremely precise indications which allow prompt **regulation of ventilation, temperature and humidity** in the chamber. The special shape of the *MultiSensor®* probe makes it **easy to remove from food** without spoiling any part of it and without the need to overheat it. The Irinox patented system of **automatic attachment to the door** facilitates its use and prevents malfunctioning.

MANUAL DEFROSTING

MultiFresh® can be defrosted manually at the end of the day.



It does not **defrost automatically during the work cycle in progress** because it is constantly able to remove all the heat from the chamber, even when it contains boiling hot food, and this prevents the formation of ice on the evaporator.

IRINOX MANUFACTURING QUALITY

Below are some details of the manufacture and functions of MultiFresh®:

- **Soft closing magnetic door closure**, softened by a high/low temperature resistant gasket.
- **Automatic switch from manual mode (timed) to automatic mode (with probe)**; MultiFresh® senses if the probe has been inserted or not.
- **Wireless** data transfer to easily download and save work process data on dedicated software (**Haccp Control Software**).
- **Maximum cleanliness and hygiene** due to rounded corners and components situated in the chamber so that they can be accessed and cleaned easily.
- **Compact condenser units** can also be provided on request in different versions: water, air, super silent and remote.
- Refrigerant gas R404.

IRINOX CERTIFICATIONS:

- **CE**: indicates that a product is compliant with the applicable EU legislation and may circulate freely within the EU 
- **EMC conformity test** (performed by an accredited independent laboratory): conformity to Directive 2004/108/CE regarding Electromagnetic Compatibility (EMC) is a compulsory requisite in Europe for obtaining the CE mark and is now becoming obligatory for an increasing number of products in countries outside the EU
- **LVD conformity test** (tested by an accredited independent laboratory): conformity to the Low Voltage Directive (2006/95/CE)
- **GOST R**: GOST-R certification for products to be exported to Russia 
- **TÜV / PED Directive 97/23/CE (Pressure Equipment Directive)** Certificate number: TIS-PED-MI-12-05-001918-5534 

UNIQUE SELLING POINTS



▪ **cETLus** (tested by an accredited independent laboratory): certifies compliance with the safety regulations in force in North America and is as widely accepted as the UL and CSA marks.



▪ **ETL Sanitation** (tested by an accredited independent laboratory): indicates compliance with NSF product safety standards. It also indicates that the manufacturer's production site conforms to a range of compliance measures and is subject to periodic follow-up inspections to verify continued conformance.



*Contains fluorinated greenhouse gases covered by the Kyoto Protocol.

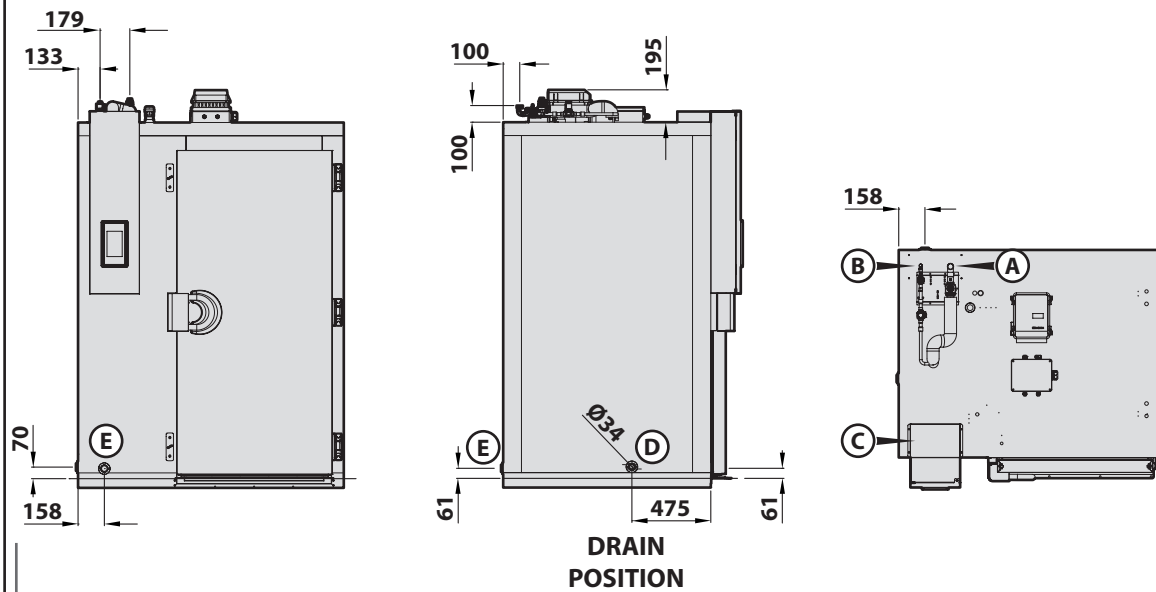
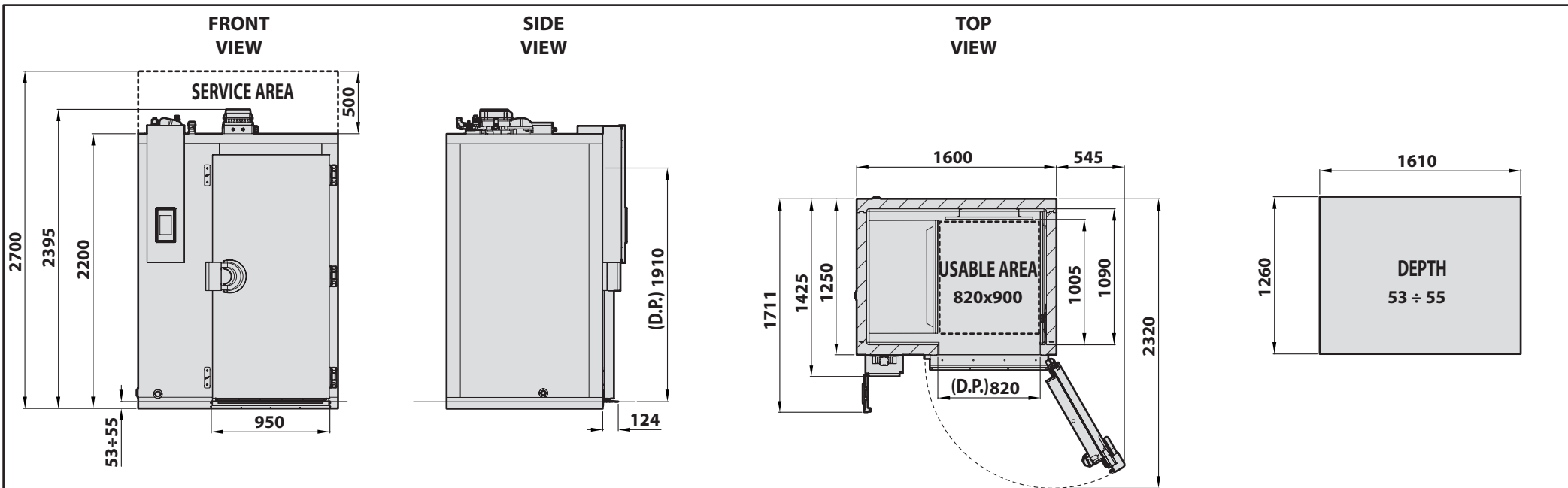

Model / Voltage	400V 3P+N+PE		230V 3P+PE	200V 3P+PE	208V 3P+PE	
	50 Hz	60 Hz	60 Hz	50/60 Hz	60 Hz	
Total rating	Kw	10,4	11,2	9,4	10,2	10,8
Total output	A	15,3	16,5	23,7	29,9	30,4
Supply cable size	mm ²	5G 4	5G 4	4G 10	4G 16	4G6 AWG
To remote condensing unit cable size	mm ²	7 x 1,5				
Gas type		R 404 A				
Liquid line connection	mm	16				
Suction line connection	mm	28				
Maximum ambient air temperature	°C	32				
Cabinet weight	Kg	480				
Internal Chamber Usable Area	l	1520				
Yeld for blast chilling cycle (90 / +3 °C)*	Kg	100				
Yeld for shock freezing cycle (90 / -18 °C)**	Kg	100				

*: within 90 Min. ** within 240 Min.

PACKING	
Gross weight	Kg 610
Dimensions (WxDxH)	mm 2550x1800x1860
Volume	m ³ 8,53

IRINOX	
Mod.: MF 100.2 PLUS - MYA	
Cod.: MF2121001SF	
Ed.: 31/10/2015	Rev.: 00

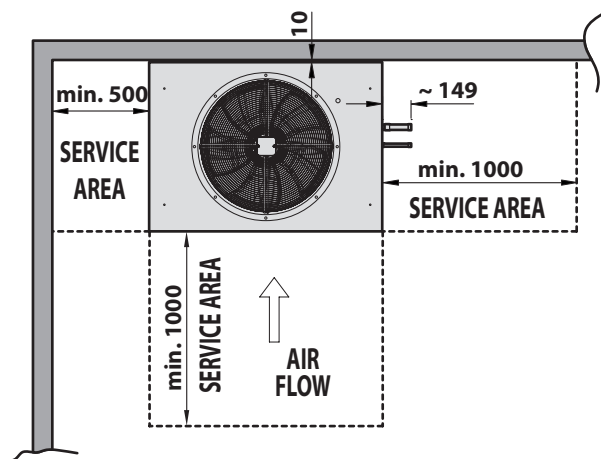
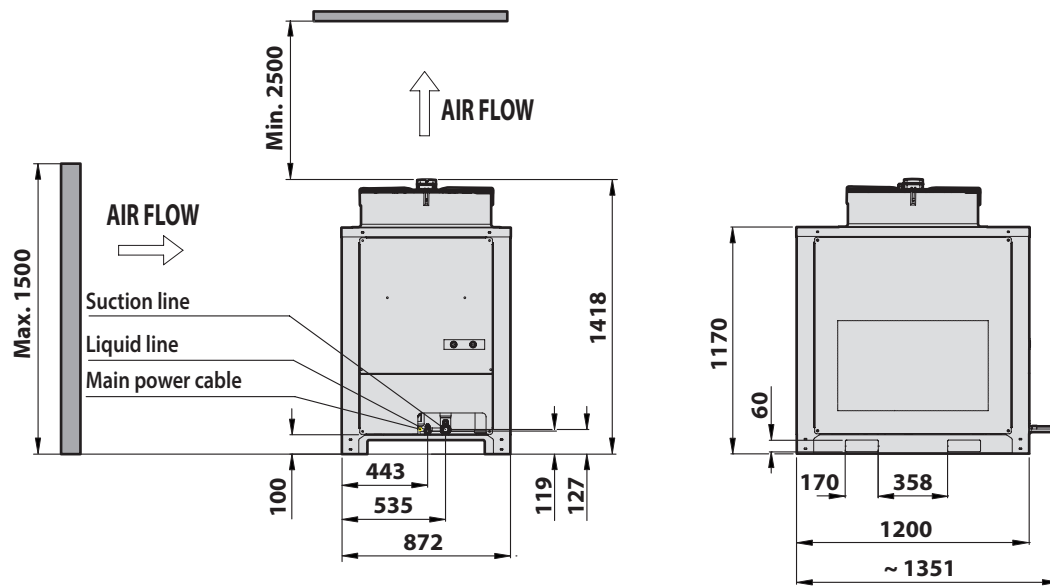

Model / Voltage	400V 3P+N+PE		230V 3P+PE		200/208V 3P+PE			
	50 Hz	60 Hz	50 Hz	60 Hz	50 Hz	60 Hz		
Total rating	kW		7	8,3	8,5	8,5	8,5	8,5
Total output	A		15,8	18,8	33,3	33,3	33,3	33,3
Supply cable size	mm ²		5G4	5G4	4G10	4G10	4G6AWG	4G6AWG
Cabinet / condensing unit connection cable:	mm ²		7 x 1,5					
Compressor rating	kW		4,9	5,87	4,9	5,87	4,9	5,87
Gas type			R 404 A					
Refrigeration Yield (-10°C evap./+40°C cond)	W		12430	14813	12430	14813	12430	14813
Condensator rating (-10°C evap./+40°C cond)	W		17330	20680	17330	20680	17330	20680
Liquid line connection	mm		16					
Suction line connection	mm		28					
Compressor displacement	m ³ /h		23,13	27,78	23,13	27,78	23,13	27,78
Minimum air circulation	m ³ /h		4545	5423	4545	5423	4545	5423
Maximum ambient air temperature	C°		42					
Net weight	Kg		200					
Gross weight	Kg		254					
Dimensions with packing (WxDxH)	mm		1630 x 1490 x 1030					
Volume with packing	m ³		2,50					
Oil Charge	l		2,8					
Compressor Noise @ 5 m (-10°C evap./+45°C cond.)	dB(A)		48					

IRINOX

Mod.: **UC100 - A**

Cod.: **UC010000**

Ed.: **10/03/2016** Rev.: **01**