

FTLD-88ETS

ELECTRIC FREELOTUS

ELECTRIC GRIDDLE 80

Electric Fry-top smooth chromed griddle
SUPERCHROME (Moca Approved), plate
cm.76x68 - 2 cooking areas



Construction - Fabricated using CrNi 18/10 AISI 304 grade Stainless Steel Scotch-Brite Satin polish Finish, incorporating 2 mm thick worktop, chromed details. Model - Professional Electric Griddle, Smooth, Ribbed or 50 / 50, Normal or Chrome. Normal Plate in FE430B Steel and Chrome in FE510C Steel. Double thermostat, operating and safety. High durability and rapid heat up. 50 - 300degC control. Fittings - Fixing system.

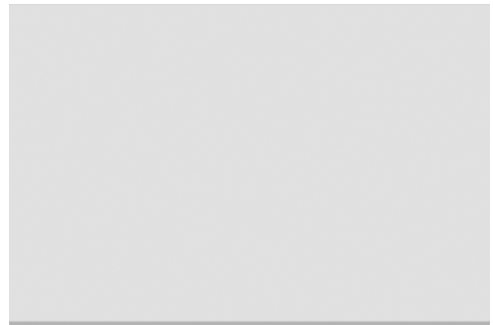

ITALIAN CULINARY ART

The pictures are purely representative. The manufacturer reserves the right to modify the technical data and models without previous notice.

FTLD-88ETS

ELECTRIC FREELOTUS

ELECTRIC GRIDDLE 80



Tabella					
Descrizione	A	B	C	D	E
FT...D-64ET	400 mm	600 mm	135 mm	51 mm	420 mm
FT...D-66ET	600 mm	600 mm	300 mm	55.5 mm	420 mm
FT...D-68ET	800 mm	600 mm	400 mm	65 mm	420 mm
FT...D-84ET	400 mm	800 mm	105 mm	29 mm	650 mm
FT...D-88ET	800 mm	800 mm	400 mm	29 mm	650 mm

A	Data plate		B	Electrical connection	
---	------------	--	---	-----------------------	--

MODEL: FTLD-88ETS
 DIMENSIONS: cm. 80x 80x 22h
 ELECTRIC POWER: 15 kW
 VOLTAGE: 400V~3N
 FREQUENCY: 50/60 Hz

kg: 90
 m³: 0.435
 mm: 830x970x540

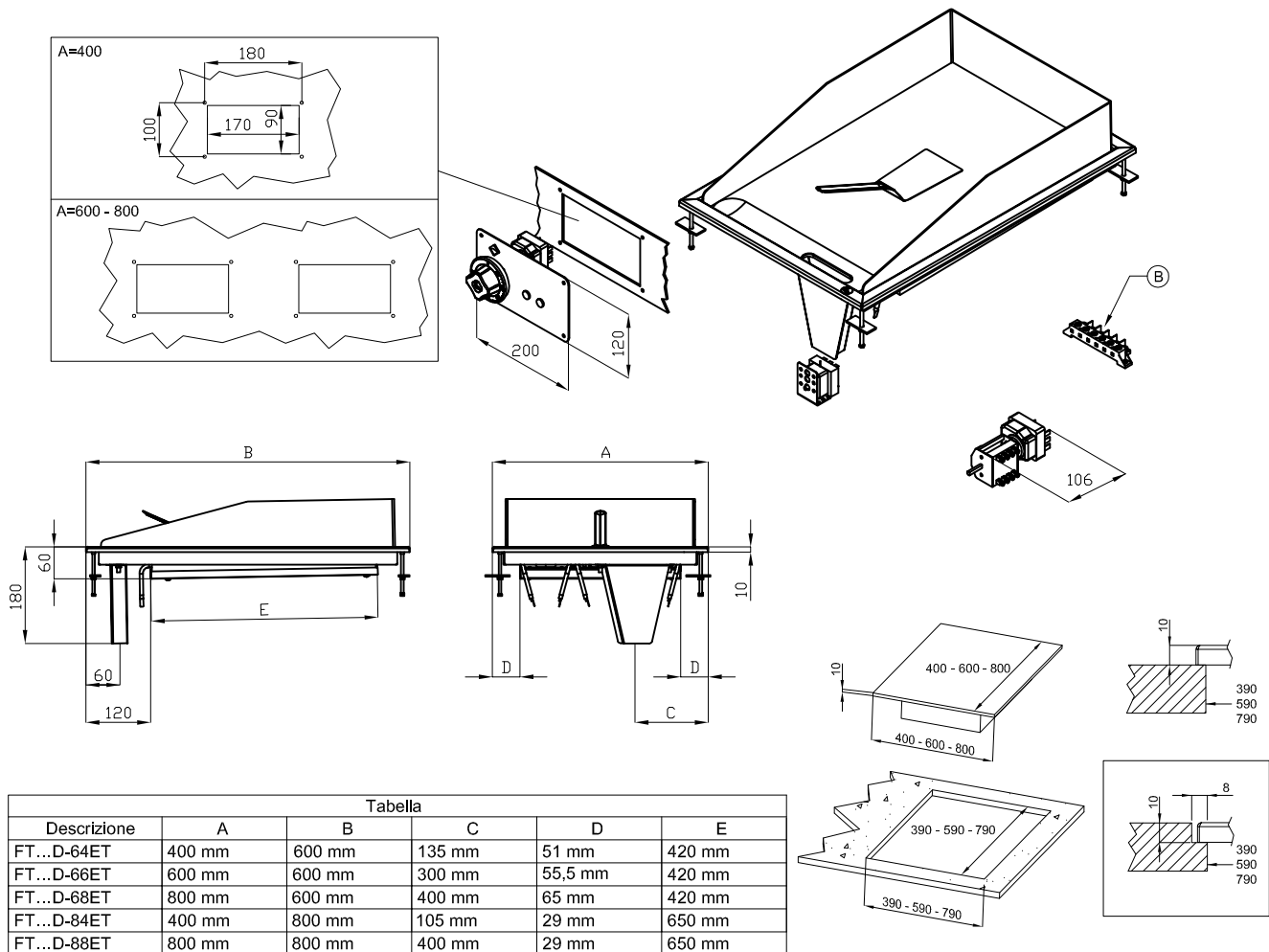
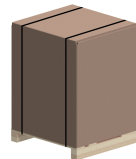

BUY LOTUS BUY ITALY

The pictures are purely representative. The manufacturer reserves the right to modify the technical data and models without previous notice.



LOTUS S.P.A. Via Calmaor, 46
 31020 San Vendemiano(TV) - Italy
 Tel. + 39 0438 778020 / 778468
 Fax + 39 0438 778277
 www.lotuscookers.it - lotus@lotuscookers.it