

FTLT-94ETS

90 IPERLOTUS TOP

ELECTRIC GRIDDLE - TOP



Electric Fry-top smooth chromed griddle
SUPERCHROME (Moca Approved), plate
cm.36x68 (included 1 Head end filler strip
mod.TPA-9)



Construction -Fabricated using CrNi 18/10 AISI 304 grade Stainless Steel Scotch-Brite Satin polish Finish, incorporating 2mm thick worktop, rounded edges, chromed details and rear splash back. Knobs with waterproof grades IPX5. Model - Professional Electric Griddle, Smooth, Ribbed or 50 / 50, Normal or Chrome. Normal Plate in FE430B Steel and Chrome in FE510C Steel. Normal or Chrome plate in chrome-molibdeno, 20mm thick, for model FTT-912. Double thermostat, operating and safety. High durability and rapid heat up. 50 - 300degC control, Removable liquid containers. Maintenance - All serviceable parts are accessible by the easy removal of front control panel. Fittings - Appliance is supplied with adjustable feet.

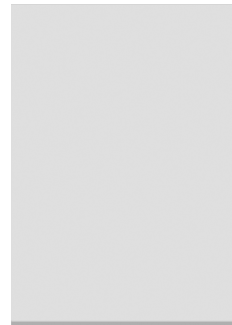

ITALIAN CULINARY ART

The pictures are purely representative. The manufacturer reserves the right to modify the technical data and models without previous notice.

FTLT-94ETS

90 IPERLOTUS TOP
ELECTRIC GRIDDLE - TOP

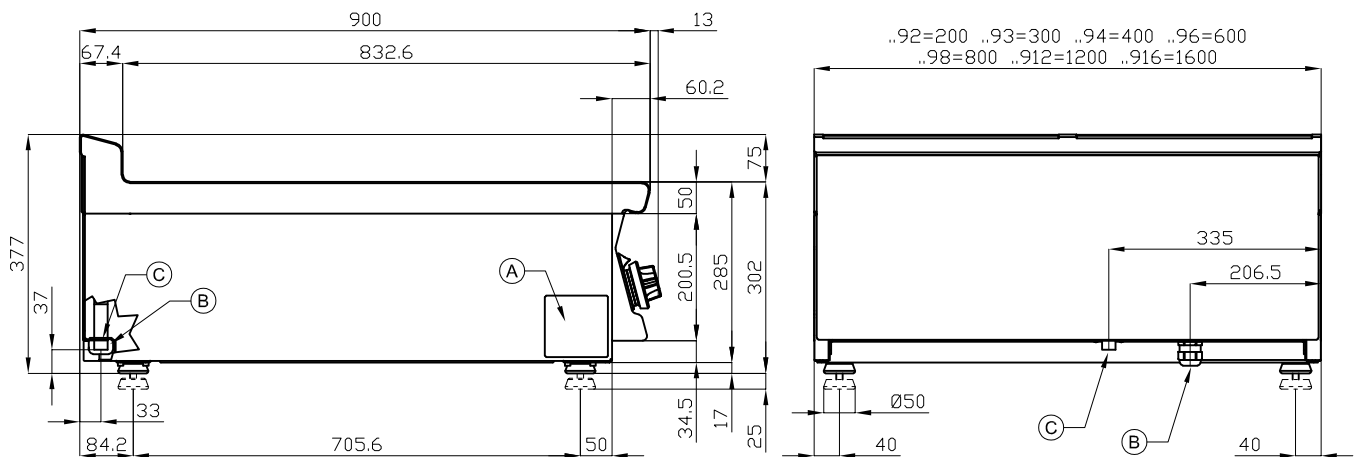

A	Data plate		B	Electrical connection	
---	------------	--	---	-----------------------	--

MODEL: FTLT-94ETS
 DIMENSIONS: cm. 40x 90x 28h
 ELECTRIC POWER: 7,5 kW
 VOLTAGE: 400V~3N
 FREQUENCY: 50/60 Hz



kg: 69
 m³: 0.225
 mm: 430x970x540

BUY LOTUS BUY ITALY

The pictures are purely representative. The manufacturer reserves the right to modify the technical data and models without previous notice.



LOTUS S.P.A. Via Calmaor, 46
 31020 San Vendemiano(TV) - Italy
 Tel. + 39 0438 778020 / 778468
 Fax + 39 0438 778277
 www.lotuscookers.it - lotus@lotuscookers.it