

DATA SHEET

Lotus F2/25-98ETDPS Electric 25L + 25L Programmable Double Tank Fryer with Auto Oil Filtration | Auto Basket Lifters

0915B832

90-SERIES



ITALIAN CULINARY ART

Build

- Professional electric freestanding double tank fryer with 25L + 25L capacity with insulated access door.
- Heavy-duty construction made from premium CrNi 18/10 AISI 304 stainless steel with Scotch-Brite satin finish. Featuring a 2mm thick worktop, rounded edges, chrome details, rear splash-back and exhaust Flue
- Dual intuitive 7" touch screen with possibility to store up to 100 programs.
- Optional modes includes an energy conservation mode at 110 °C and a preworking at 160 °C easily accesible from the main touch screen.
- High-efficiency rapid recovery sheathed elements effortlessly heat oil with minimal heat loss.
- Easy Tank Cleaning utilizes a specially designed rotating heating element, creating clear space for effective sanitizing and ensuring all areas of the tank are thoroughly cleaned.
- Oil presence sensor and maximum level sensor ensures the fryer is topped up with oil automatically and without operator intervention.
- Dual automatic oil filtration pump filters the hot oil at max 180°C ensuring long oil life, crystal clean oil on demand and oil tank emptying. The oil collection basin is on wheels for easy accesibility and can filter up to 5 microns (includes 100 envelope filters).
- Includes four frying basket with single front grip, measuring 13 cm W x 45 cm D x 21 cm H with 2 integrated Lifter for baskets, along with a drip tray with sieve.
- Fully insulated dual Stainless Steel frying tanks each measuring 31 cm W x 51 cm D x 33 cm H
- Designed for easy maintenance and serviceability, with all parts accessible by simply removing the front control panel.



Technical specifications

External Size

External Width	800mm
External Depth	900mm
External Height	900mm

Weight

Net weight	
package weight	166 kg

Technical Features

Element Power	45.3 kW
Tank Type	Double
Frying Basket Size (each)	13.5cm W x 45cm D x 21cm H
Frying Tank Size (each)	31cm W x 51cm D x 33cm H
Frying Tank Capacity	25L + 25L
Production	60 kg/h

Connection requirements electric

Electrical connected loads	45.3 kW
Voltage	400V~3N
Plug Supplied	No

Warranty

2 Year Warranty	2 years parts and labour
-----------------	--------------------------

**Subject to a preventitive maintenance plan*

DATA SHEET



ITALIAN CULINARY ART

Lotus F2/25-98ETDPS Electric 25L + 25L Programmable
 Double Tank Fryer with Auto Oil Filtration | Auto Basket Lifters
 0915B832 90-SERIES

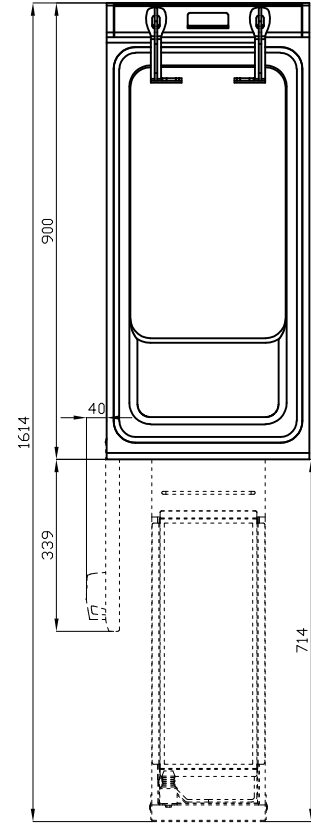
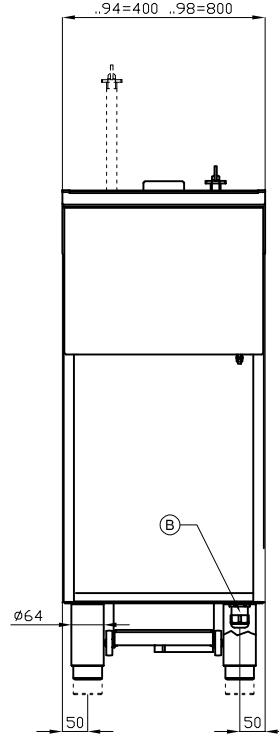
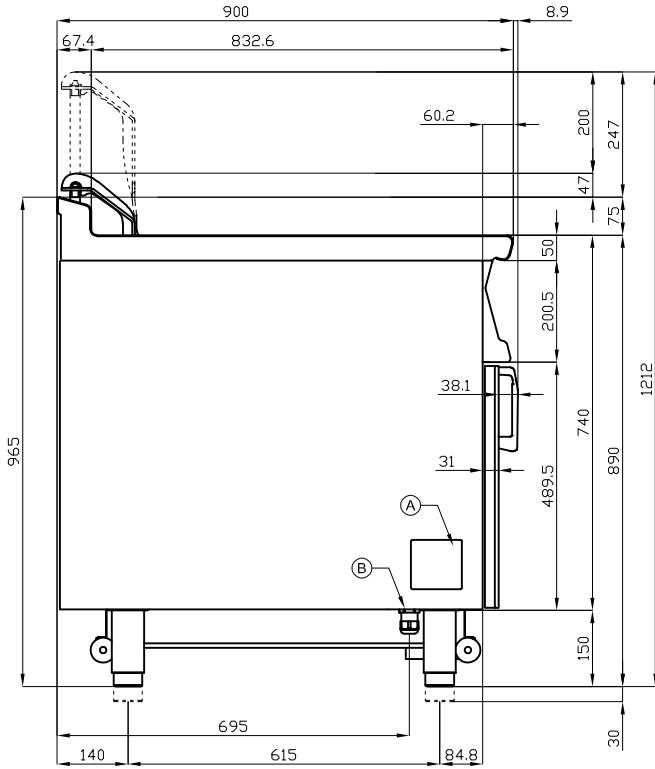

A	Data plate
B	Electrical connection

We reserve the right to alter specifications without notice.



1800 183 818

support@thegoodlady.com.au

www.thegoodlady.com.au