

# F2/25-98ETDP

90 IPERLOTUS

ELECTRIC ELECTRONIC FRYER



Electric electronic Fryer with a 7" TouchScreen. Conservation at 110 °C and preworking at 160 °C with or without Melting. Possibility to store in the memory up to 100 programs. Oil presence sensor and maximum level sensor. 2 pump for filter the hot oil max 180°C, Tank cleaning, Tank emptying. 2 bowl 25 lts cm.31x51x33h - 4 baskets cm.13,5x45x21h. 2 Sieve and lid for pan. 2 Oil collection basin with support on wheels with sieve 5 microns (pcs.100 included). Production: 60 kg/h (included 1 Head end filler strip mod.TPA-9)



ITALIAN CULINARY ART

The pictures are purely representative. The manufacturer reserves the right to modify the technical data and models without previous notice.

# F2/25-98ETDP

90 IPERLOTUS

ELECTRIC ELECTRONIC FRYER

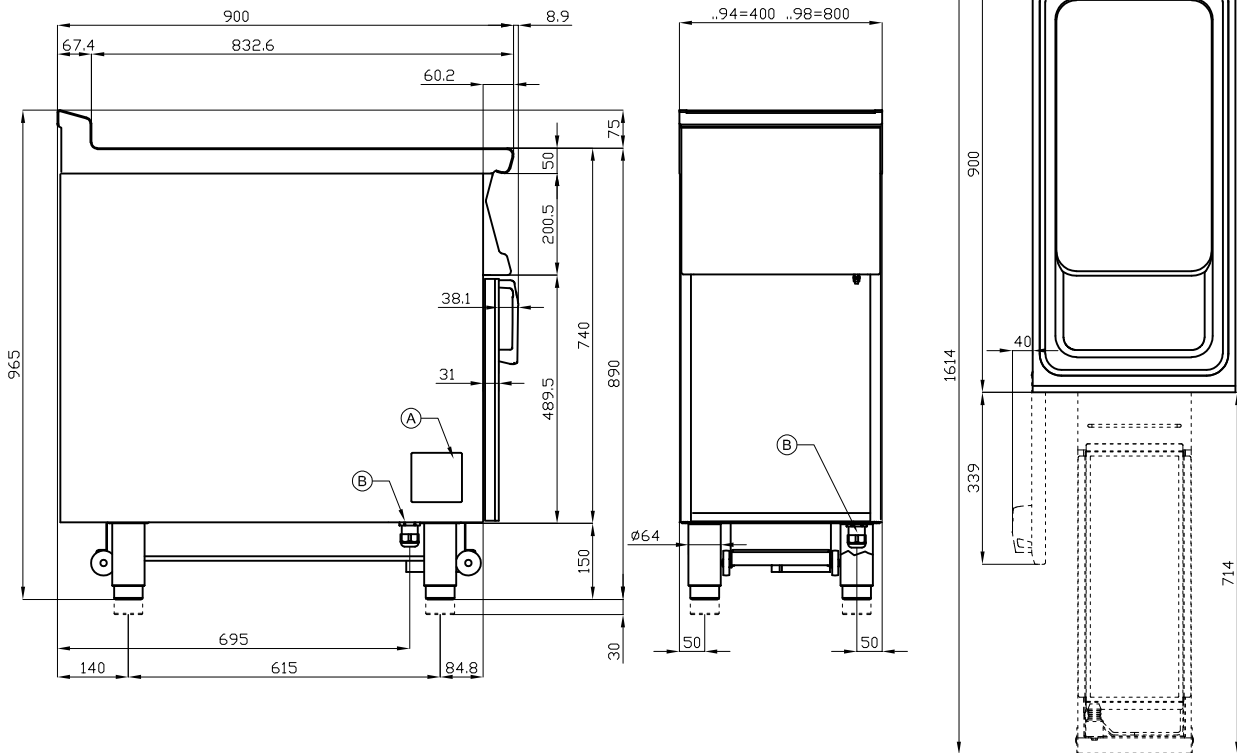

A	Data plate	B	Electrical connection
---	------------	---	-----------------------

MODEL: F2/25-98ETDP  
 DIMENSIONS: cm. 80x 90x 90h  
 ELECTRIC POWER: 44,6 kW  
 VOLTAGE: 400V~3N (2x)  
 FREQUENCY: 50/60 Hz



kg: 146  
 m<sup>3</sup>: 1.047  
 mm: 830x970x1300

BUY LOTUS BUY ITALY

The pictures are purely representative. The manufacturer reserves the right to modify the technical data and models without previous notice.



LOTUS S.P.A. Via Calmaor, 46  
 31020 San Vendemiano(TV) - Italy  
 Tel. + 39 0438 778020 / 778468  
 Fax + 39 0438 778277  
 www.lotuscookers.it - lotus@lotuscookers.it