

PI50-78ET

70 SUPERLOTUS ELECTRIC KETTLE

Electric indirect boiling pan 50 lts. Tank Ø
cm. 40x45h (included 1 Head end filler strip
mod.TPA-7)



Construction - Fabricated using CrNi 18/10 AISI 304 grade Stainless Steel Scotch-Brite Satin polish Finish, incorporating 2 mm thick worktop, rounded edges, chromed details and rear splash back. Knobs with waterproof grades IPX5. Model - Professional Electric Kettle, possible automatic water-charge of double jacket. Indirect version available. 50ltr tank constructed in AISI 304 with AISI 316 bottom. Easy and safe open and closing system. Thermostatic control. Maintenance - All serviceable parts are accessible by the easy removal of front control panel. Fittings - Appliance is supplied with adjustable feet.



ITALIAN CULINARY ART

The pictures are purely representative. The manufacturer reserves the right to modify the technical data and models without previous notice.

PI50-78ET

70 SUPERLOTUS
ELECTRIC KETTLE

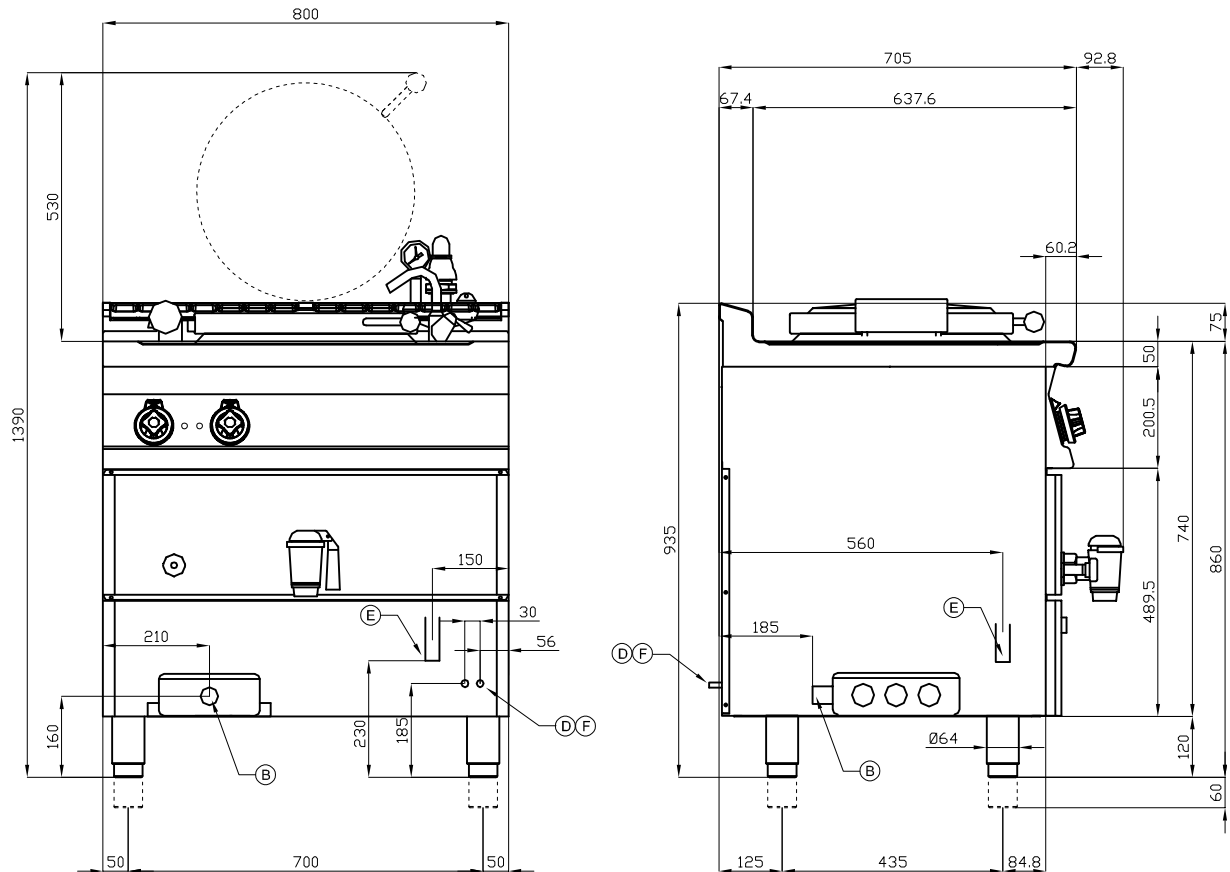

A	Data plate		B	Electrical connection	
D	Cold water connection	Ø10mm	E	Water drainage	Ø25mm
F	Hot water connection	Ø10mm			

MODEL: PI50-78ET
 DIMENSIONS: cm. 80x 70,5x 90h
 ELECTRIC POWER: 9 kW
 VOLTAGE: 400V~3N
 FREQUENCY: 50/60 Hz



kg: 120
 m³: 0.709
 mm: 830x770x1110

BUY LOTUS BUY ITALY

The pictures are purely representative. The manufacturer reserves the right to modify the technical data and models without previous notice.



LOTUS S.P.A. Via Calmaor, 46
 31020 San Vendemiano(TV) - Italy
 Tel. + 39 0438 778020 / 778468
 Fax + 39 0438 778277
 www.lotuscookers.it - lotus@lotuscookers.it