

# GGU 1550

Table-height freezer with static cooling

Premium

INDUSTRY  
KITCHENS

[www.industrykitchens.com.au](http://www.industrykitchens.com.au) 1800 611 058



**LIEBHERR**

Freestanding

# GGU 1550

Table-height freezer with static cooling  
Premium



Gross/net capacity	143/133 litre
Ext. dimensions in mm (w/d/h)	600/615/830
Int. dimensions in mm (w/d/h)	474/443/676
Energy consumption in 365 days / 24 hours (kWh)	599 / 1.64
Ambient temperature range	+10°C to +43°C <sup>1</sup>
Refrigerant	R 600a
Connection Rating	0.6 A / 60 W
Frequency / Voltage	50 Hz / 220-240 V~
Cooling system	static
Defrosting	manual
Temperature range	-9°C to -26°C
Housing material/colour	stainless steel/stainless steel
Door material	Stainless steel
Liner Material	moulded polystyrol white
Type of Control	electronic controller
Automatic SuperFrost function	yes
Temperature display	external digital
Fault: warning signal	visual and audible
Number of baskets	4
Shelves, freezer compartment	4
Compartment height in mm	3 × 150, 1 × 170
Lock	fitted
Door hinges	right, reversible
Gross/net weight	42/39 kg
EAN-Nr.	9005382167274

<sup>1</sup> Indicates the ambient temperature at which the device can be operated safely.



## Features

---



### Reversible door hinges (left/right)

Liebherr appliances are factory-fitted with door hinges on the right. The ability to change the hinge side allows the appliance to be tailored to individual requirements and optimally positioned.



### Environmentally friendly refrigerants

Liebherr appliances are optimised for maximum energy efficiency and low operating costs. We only use the natural and environmentally-friendly refrigerants R 600a and R 290. When used with highly efficient compressors, these are extraordinarily efficient and, with their low global warming potential, also future-proof.

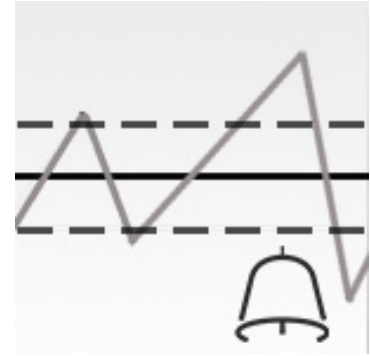

### Temperature alarm

The integrated temperature alarm indicates if the lower or upper alarm thresholds have been breached. It uses both acoustic and visual signals to provide maximum security for goods that have been stored.



### Efficient refrigeration system

Liebherr guarantees the outstanding quality of its refrigeration systems through expertise derived from decades of experience in the refrigeration technology sector, and through continuous research and development. By employing only premium-quality compressors, condensers, evaporators and other refrigeration components the energy consumption and operating costs of Liebherr appliances are significantly reduced.



### Stainless steel housing

The outer housing is constructed using single-sheet side panels without any gaps, making it extremely hygienic and easy to clean. Stainless steel is a highly robust, stainless, alloy steel – perfect for the requirements of the professional sector.

Freestanding GGU 1550

**LIEBHERR**

# Technical drawing

---

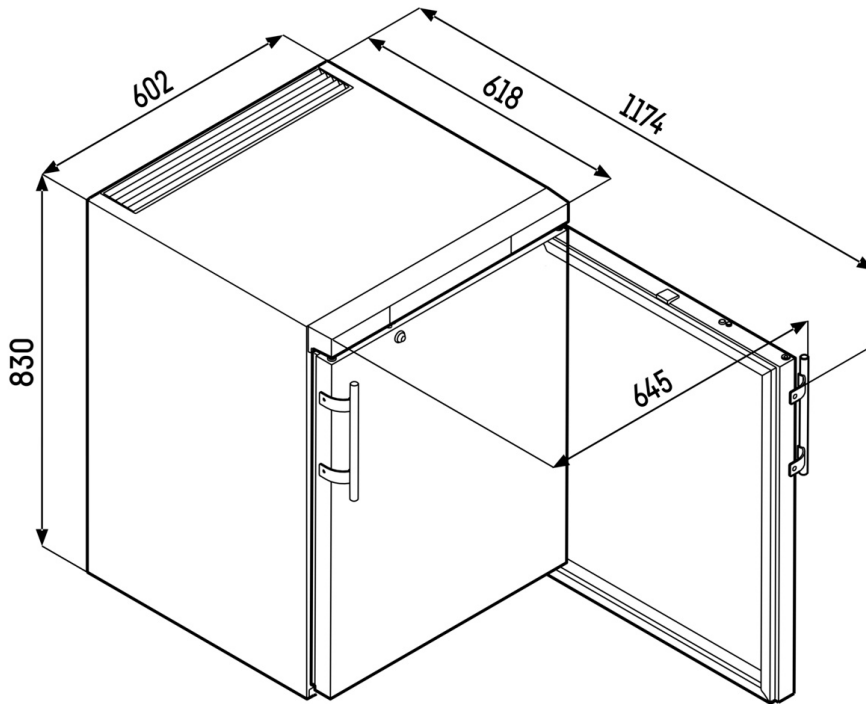

---

Products and their details are staged for advertising purposes. Whilst every effort is made to ensure all specifications and information in this flyer are accurate, Liebherr reserves the right to make changes without notification. Where actual appliance measurements, specifications, and ratings are crucial, we recommend that the actual appliance installation instructions that accompany each appliance be checked. Liebherr will not be liable for any damage. (29.11.2023)



[home.liebherr.com](https://www.home.liebherr.com)