

# WZ 1500mm Waterless Woks



## Technical Specifications for WZ-2C2B



**INDUSTRY  
KITCHENS**

www.industrykitchens.com.au 1800 611 058

### Waterless Wok

- 110 mj 24 jet chimney burners with pilot & FFD
- 333mm diameter standard size cast-iron wok ring
- 28 mj side burners with FFD standard (pilots extra)
- Air gap cooling system
- Quarter turn water control lever
- Folding rear laundry arm with front panel controls
- Wider front gutter design for easier cleaning
- Internal front heat shield panel
- Supplied with waste strainer
- Zinc-aluminium Alloy burner handles

### Overall Construction

- Heavy duty construction
- Full skirt, enamelled cast-iron rings
- 1.5mm 304 stainless steel one-piece pressed deck
- 0.9mm 304 stainless steel condiment shelf
- Splashback and front cover 1.2 mm 304 stainless steel
- Integrated hob 1.5mm 304 stainless steel
- Side panels 1.2mm 304 stainless steel
- Undertrays 0.9mm stainless steel
- Stainless steel removable legs
- 30mm height adjustment range

### Dimensions

- 1500mm x 800mm x 1300mm H
- Working height 800mm
- Weight 190kg
- Packed dimensions 1550mm x 900mm x 1470mm H
- Packed weight 230kg

### Connections

- Gas 3/4" BSP female
- Gas 294/421/1021mm from right, 84mm to rear, 425mm to floor
- Supplied with gas regulator (specify Nat or LP on order)
- Water inlet 1/2" copper tube
- Water 61mm from right, 81mm to rear, 408mm to floor
- Drain 1 3/4" BSP male, drain outlet 2"
- Drain 122mm from left, 83mm from rear, 590mm to floor

### Cleaning & Servicing

- Easy access to all parts & components from front

### Options/Accessories

- Knee lever timer tap
- Replace Chimney burners with Duckbill or Dual Ring burners
- 250mm and 500mm wide clip on shelves (front)
- Wok Holder
- Clip On Sauce Holder
- Injector Cleaning Tool
- Joining caps & strips
- RH and LH side shields
- Rear castors

## ASIAN

- Space saving 800mm total unit depth
- 333mm wok ring suitable for standard sized woks
- Chimney burners ideal for high heat/fast stir frying
- Uses up to 90% less water than Traditional Woks
- Air gap design eliminates need for water cooling
- Machine pressed deck to prevent grime catchment
- Concealed ring lip prevents water from entering air gap
- Removable, vented rear condiment shelf
- Modular design to suit multiple WZ wok units
- Optional Duckbill and Dual Ring Burners no additional cost
- Optional configuration with side burners on LHS
- 24 month 'Platinum Warranty'
- Easy to clean and service

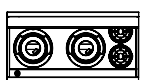
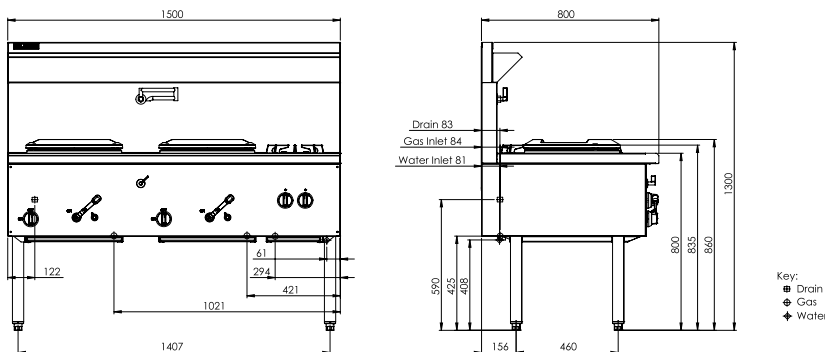

Model	Description	Nat Gas	LP Gas
WZ-2C2B	2 chimney wok, 2 open burners	276 mj	276 mj

Chimney Burners are designed to be run at full strength and not turned down. Turning burner down may lead to incomplete combustion and sooting.

