

PRODUCT FEATURES

- Individual premium crescent cube with no ice bridging.
- Exceptionally hard crystal clear cubes that melt slowly.
- Durable stainless steel exterior.
- Slide in air filter for easy cleaning - maintaining performance efficiency.
- Patented double sided stainless steel evaporator for all water conditions - produces more ice in less cycles.
- Audible alarms.
- 3 year parts & labour on entire unit, 5 year parts & labour on the evaporator, 5 year (parts only) on compressor and air cooled condenser coil.

CUBE SIZE:

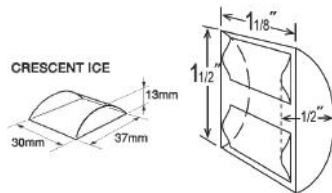

TECHNICAL DRAWING

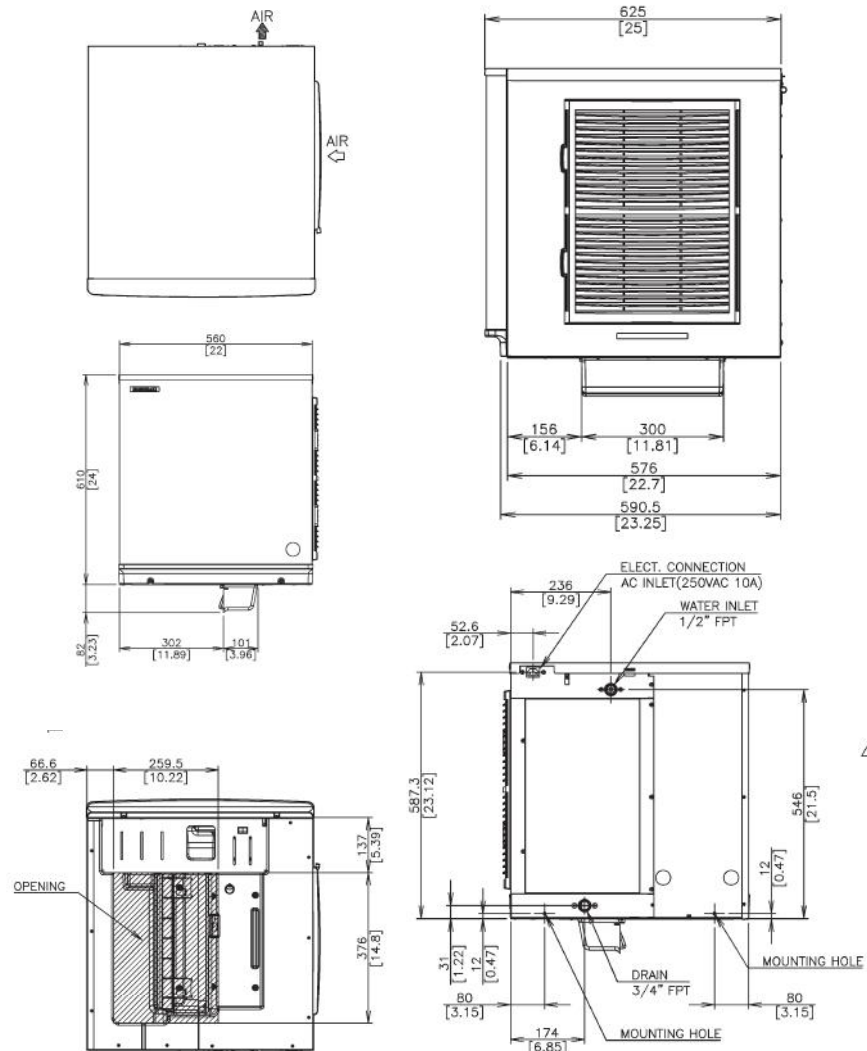

PRODUCT SPECIFICATION

Production Capacity per 24hours	Approx. 200 kg @10°C Air temp; 10°C Water Approx. 175 kg @21°C Air temp; 21°C Water Approx. 140 kg @ 32°C Air temp; 32°C Water
Max Storage Capacity	Select Bin and Kit
Freeze Cycle Time	Approx. 30.5(AT. 21°C, WT. 15°C)
Ice Production Per cycle	Approx. 3.7 kg / 416pcs(AT. 21°C, WT. 15°C)
Dimensions	560mm (W) x 625mm (D) x 610mm (H) (Not incl. Bin Sw)
Cooling	Air
Weight Net/Gross (kg)	57 / 73
AC Supply Voltage	1 PHASE 220-240/230V 50/60 Hz /10amp Plug
Amperage	3.0/3.6A (AT. 32°C, WT. 21°C)
Refrigerant Charge	R404A / 520g
Operating Conditions	Ambient Temp.: 7-40°C Water Supply Temp.: 7-35°C Water Supply Pressure: 0.07-0.8MPa (0.7-8bar) Voltage Range: ±6%