

ARTISANAL LINE

PERFECT BATCH FREEZING FOR A SURPRISINGLY CREAMY RESULT

Innova's Movi is the electronic horizontal professional batch freezer of the latest generation: a functional, practical, robust and reliable work tool. Innova's patented blade ensures absolute hygiene inside the cylinder, a perfect creamy mixture and complete extraction of the ice cream at the end of each work cycle. Movi is equipped with highly efficient motors to ensure the lowest amount of energy consumption in full respect of the environment.

Production 100% Made in Italy. Movi is made by Innova in Bergamo, Italia using only the highest quality materials. The robust structure is entirely made of stainless steel aisi 304, specific for food, with a self-supporting chassis that is very thick, although compact.

Energy savings. The combined use of 2 inverters, to control the consumption of electrical energy, and of a highly energy efficient class IE3 gear motor for a direct transmission of motion, ensures considerable energy savings.

Time savings. Fast batch freezing cycle, only 6 minutes for a perfect gelato. Fast cleaning and sanitizing thanks to the simple release system of the blade with the female coupling that leaves the cylinder hermetically sealed for a perfect cleaning.

Safety. The Remote Control System (RCS) directly connects the machine to Innova's service network, which can view the settings of the functions in real time and thus provide a targeted solution to your issues.

Tranquility. Innova is reliable like no other, the first and only to offer a 5-year warranty on all artisanal ice cream machines. The Plus Program is the exclusive voucher plan conceived to protect your Innova ice cream machine in case of any need of maintenance.

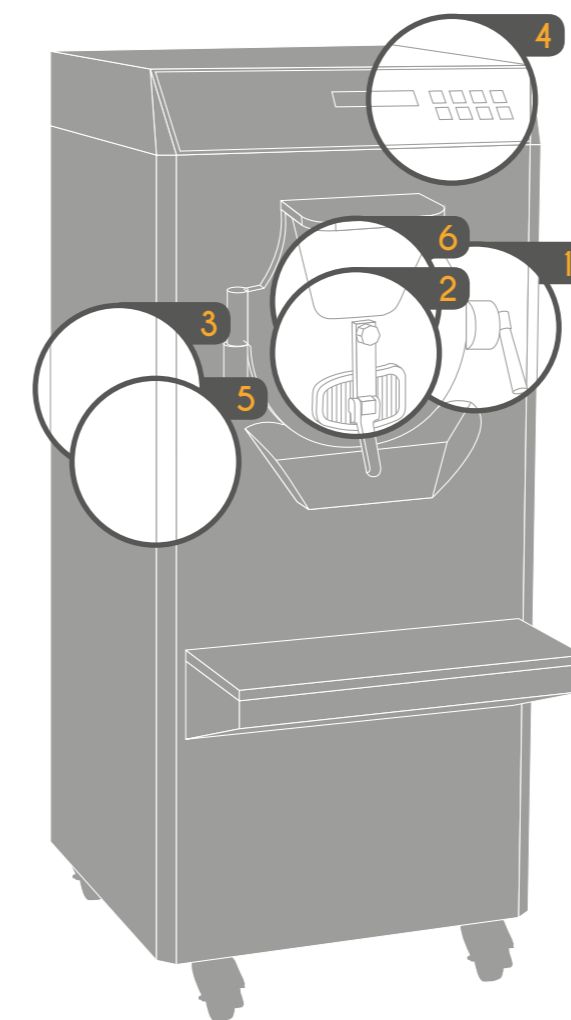

Only with us!

A PLUS OF EXCELLENCE
5 YEARS OF WARRANTY

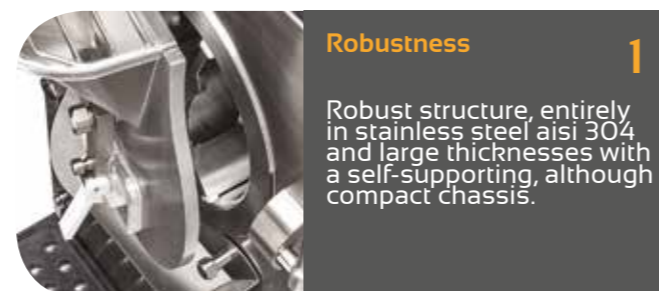

Robustness

Robust structure, entirely in stainless steel aisi 304 and large thicknesses with a self-supporting, although compact chassis.



Fast work cycle

In just 6 minutes, Movi allows to turn the mixture into a perfect gelato and thanks to the patented blade and self-expanding spatulas, the cylinder can be completely emptied without any waste during extraction.

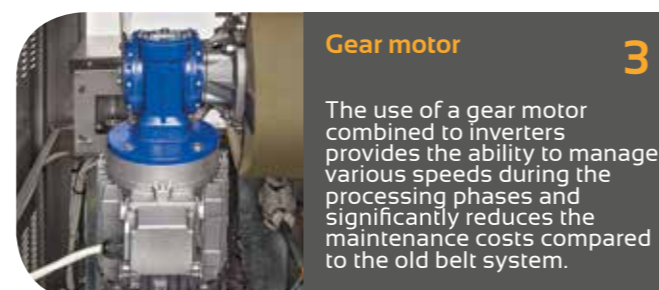

Gear motor

The use of a gear motor combined to inverters provides the ability to manage various speeds during the processing phases and significantly reduces the maintenance costs compared to the old belt system.

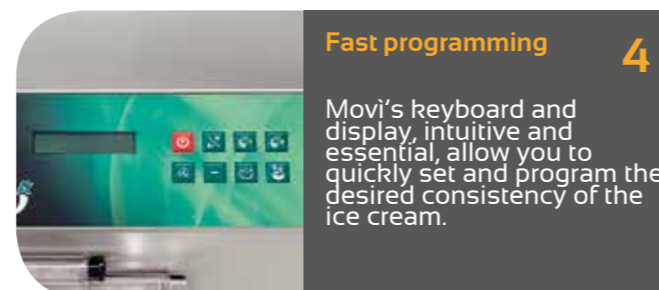

Fast programming

Movi's keyboard and display, intuitive and essential, allow you to quickly set and program the desired consistency of the ice cream.

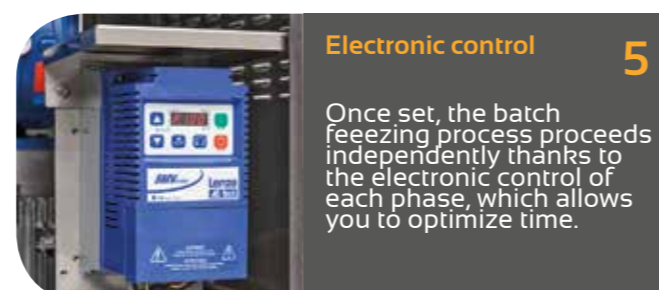

Electronic control

Once set, the batch freezing process proceeds independently thanks to the electronic control of each phase, which allows you to optimize time.

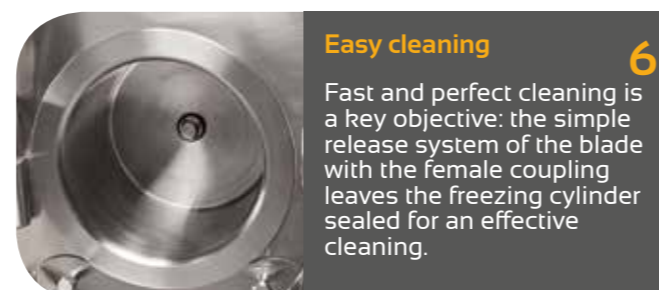

Easy cleaning

Fast and perfect cleaning is a key objective: the simple release system of the blade with the female coupling leaves the freezing cylinder sealed for an effective cleaning.



INNOVA
www.innovaitalia.com
movi 18

A+
SYSTEM

A PLUS OF EXCELLENCE
5 YEARS OF WARRANTY

100% MADE IN ITALY

movi

ELECTRONIC BATCH FREEZER

INNOVA
LE MACCHINE PER IL GELATO

A+

The technology that gives you more!

The A+ batch freezers, the A+ multifunction and the A+ pasteurizers are the latest generation of ice cream machines that use the A+ system made by INNOVA, thanks to the use of inverters in cooling management.

THE ADVANTAGES OF THE A+ SYSTEM ARE:

- INGREDIENTS ARE QUICKLY CRYSTALLIZED BY A BALANCED QUANTITY OF COLD TO ACHIEVE PERFECT CREAMINESS.
- THE ICE CREAM NEVER FREEZES THANKS TO THE AUTOMATIC MODULATION OF THE THERMAL POWER OF THE COMPRESSOR AT ANY STAGE OF PROCESSING.
- CONSIDERABLE ENERGY SAVINGS.
- FLEXIBILITY IN THE MANAGEMENT OF THE DIFFERENT AMOUNTS OF ICE CREAM.
- PERFECT EXTRACTION THANKS TO THE CONTROLLED COOLING THAT MAINTAINS THE HIGH QUALITY OF THE PRODUCT.

MOVI & SMART

ARTISANAL LINE

TECHNICAL SPECIFICATIONS

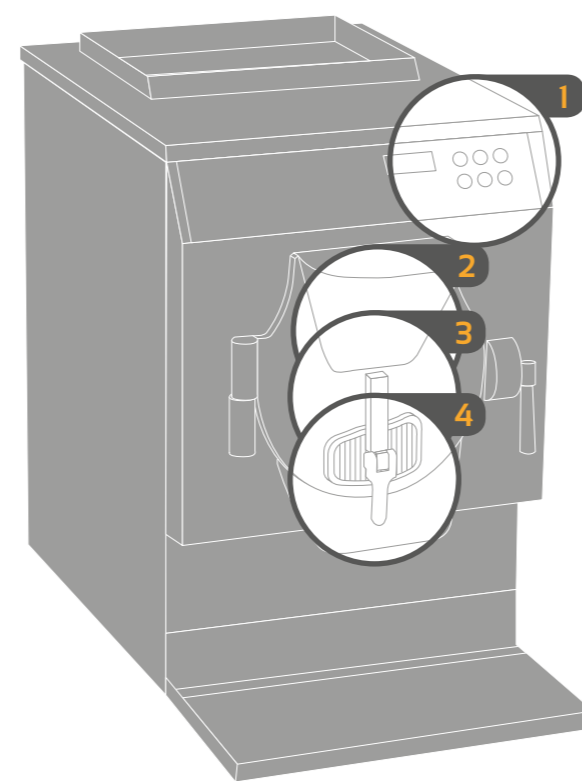

	MOVI 30 SMART	MOVI 30	MOVI 30 A+	MOVI 60	MOVI 60 A+	MOVI 100	MOVI 100 A+
Power source	400/50/3	400/50/3	400/50/3	400/50/3	400/50/3	400/50/3	400/50/3
Power	5 kw	5 kw	4.5 kw	7 kw	6.5 kw	7.5 kw	7 kw
Condensation	Air	Water	Water	Water	Water	Water	Water
Hourly Prod.	20-35 kg	20-40 kg	20-40 kg	35-60 kg	20-60 kg	45-100 kg	35-100 kg
Load cycle	2 - 6 lt	2 - 6 lt	1,5 - 6 lt	4 - 10 lt	2,5 - 10 lt	6 - 13 lt	4 - 13 lt
Tecnology	1 inverter	1 inverter	2 inverter	1 inverter	2 inverter	1 inverter	2 inverter
Width	58 cm	61 cm	61 cm	61 cm	61 cm	61 cm	61 cm
Depth	72 (+20) cm	60 (+25) cm	60 (+25) cm	60 (+25) cm	60 (+25) cm	80 (+25) cm	80 (+25) cm
Height	83 cm	143 cm	143 cm	143 cm	143 cm	143 cm	143 cm
Weight	205 kg	225 kg	225 kg	265 kg	265 kg	290 kg	290 kg



Electronic control 1

Once set, the batch freezing process proceeds independently thanks to the electronic control of each phase, which allows you to optimize time.

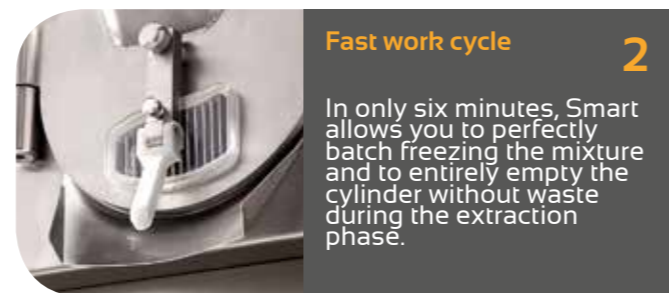

Fast work cycle 2

In only six minutes, Smart allows you to perfectly batch freeze the mixture and to entirely empty the cylinder without waste during the extraction phase.

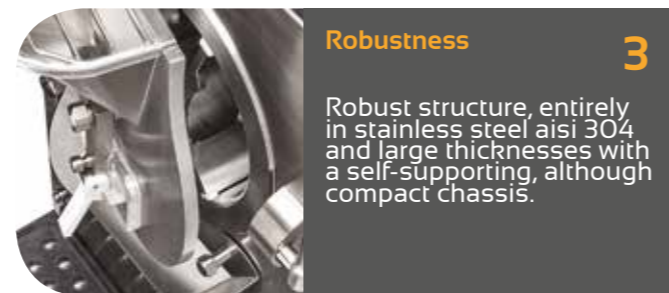

Robustness 3

Robust structure, entirely in stainless steel aisi 304 and large thicknesses with a self-supporting, although compact chassis.

MAXIMUM PERFORMANCE, MINIMUM SIZE

Smart is the electronic counter-top batchfreezer of the latest generation: a model that has structural features and a functional potential of the highest level. Thanks to the compact dimensions, to the absolute mobility and to the air cooling system, it can easily be placed in any space while ensuring in energy consumptions. Smart can continuously produce up to 35 kg of ice cream an hour with.

Production 100% Made in Italy.

Smart is made by Innova in Bergamo, Italia using only the highest quality materials. The robust structure is entirely made of stainless steel aisi 304, specific for food, with a self-supporting chassis that is very thick, although compact.

Energy savings.

The combined use of a series inverters, to control the consumption of electrical energy, and of a highly energy efficient class IE3 gear motor for a direct transmission of motion, ensures considerable energy savings.

Technical support with remote control.

Thanks to the Remote Control System (RCS), Innova's service network can view the settings of the functions in real time.



Easy cleaning 4

The simple release of the blade with the female coupling leaves the cylinder of the batch freezer sealed for a quick, effective and complete cleaning of the machine when using the cleaning button.



A PLUS OF EXCELLENCE
5 YEARS OF WARRANTY
 100% MADE IN ITALY

INNOVA
 LE MACCHINE PER IL GELATO

via Lentino, Loc. Cedrini - 24020 CERETE (BG) - Italy
 ph. +39 0346 63497 - fax +39 0346 640838

Innova le macchine per il gelato

www.innovaitalia.com

Smart

ELECTRONIC COUNTER-TOP BATCH FREEZER

INNOVA
 LE MACCHINE PER IL GELATO