

# THREE FLAVOR STAND TYPE SOFT ICE CREAM MACHINE



# SSI-203SN (P)

W x D x H (mm)  
(530) x (900) x (1,515)



## Feature



SIMPLICITY



PERFORMANCE



RELIABILITY



EXCELLENT TASTE



**Direct Motor Drive (operation)**

Less noise & Less vibration



**Mix Hopper**

One, 10 liter (2.64 gallon) x 2EA / Maintain the temperature of mix, under 5°C (41°F) in Auto & Standby modes



**Freezing Cylinder**

One, 2.7 liter (0.72 gallon) x 2EA



**Artificial Intelligence Control System**

A.I Control System makes high quality soft serve ice cream.



**(P)\*Model has Air Pump System**

Air Pump increase overrun which makes Soft Serve Ice Cream much smoother and softer

## Dimensions

Dimensions	Net	Gross
Width	530 mm	615 mm
Depth	900 mm	930 mm
Height	1,515 mm	1,685 mm
Weight	586 lbs(266 kg)	654 lbs(296.5 kg)

### Certification



# THREE FLAVOR STAND TYPE SOFT ICE CREAM MACHINE

## Dimension – Unit : mm (inch)

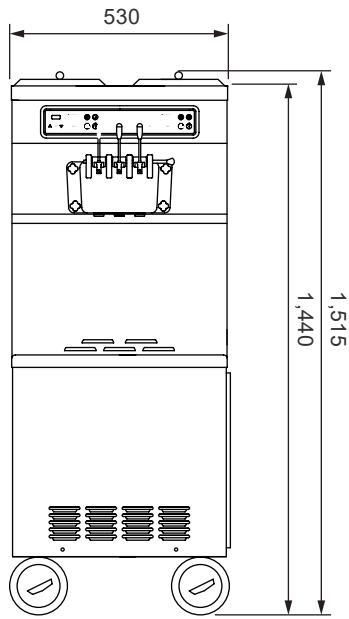

FRONT

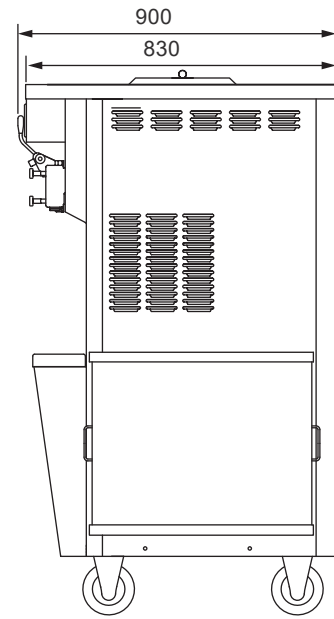

RIGHT SIDE

## Specification

Model	Mix Hopper Capacity	Cylinder Capacity	Consecutive Dispensing	Dasher Motor	Max. Production	First Dispensing
ISI-203SN(P)	10 liter (2.64 gallon) x 2EA	2.7 liter (0.72 gallon) x 2EA	16~40 cups (100 cc/3.5 oz)	0.75 KW x 2EA	42 kg (92.6 lbs/h)	7~11 min
	Cylinder Compressor	Power Consumption	Mix Hopper Compressor	Cooling System	Electrical Option	
	1 HP x 2EA (R-404A)	4,500 W	0.35 HP (R-134A)	Air-Cooled	220~240V/50Hz/1PH 208~230V/60Hz/1PH 380~420V/50Hz/3PH 208~230V/60Hz/3PH	

※ Production Capacity may vary depending on ambient temperature.

## Detail View



Simple & Easy to access operating / control system on the front touch panel



Pull out to remove the Air filter at the bottom of the right side

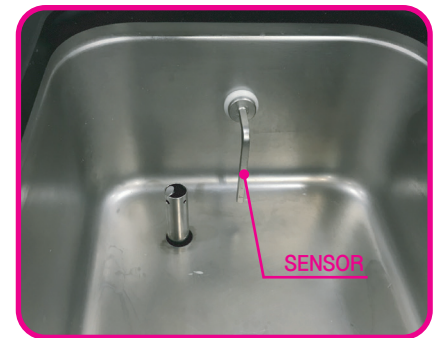

Automatically Detect MIX OUT & MIX LOW by the sensor

※ Design and Specification are subject to change without notice.