



UCG105A

## Features

- Produces clear, long-lasting gourmet cubes.
- Space-saving 463 mm wide under-counter design.
- Produces up to 47.5 kg of ice per day.
- Castors optional - bringing height down to 839mm
- Constructed from sturdy, corrosion-resistant stainless steel and fingerprint-proof plastic.
- Ideal for any under-counter or bar application.
- Contemporary, elegant design.
- Environmentally friendly R134A refrigerant.
- Easily adjust the thickness of your ice from the front of the machine!

## Space-Saving Solutions

- Front air discharge design for compact spaces.
- Low profile top saves counter space.
- Stores up to 22 kg of ice.
- Easy front access to ice.
- Removable Air Filter.

## Options & Accessories

WATER FILTERS		
Ice Machine Model	Manifold	
	System	Replacement
UCG105	CD10B	CD100B

## Ice Maker Warranty

Every Ice-O-Matic ice maker is backed by a warranty that provides both parts and labor coverage.

- Two years Parts and Labour

## Ice Form



GOURMET ICE

### GOURMET ICE DIMENSIONS

Height	30.5 mm
Diameter	34.25 mm

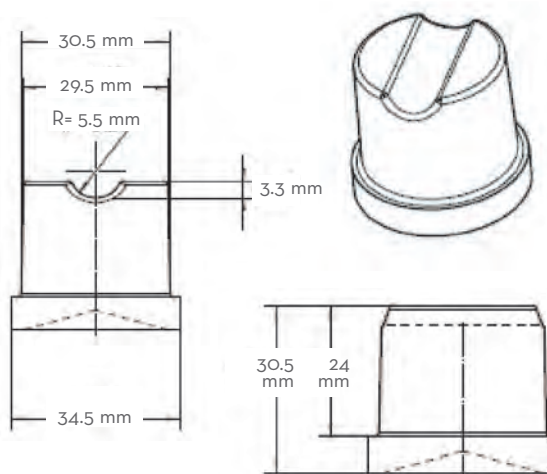

UCG105A GOURMET SERIES UNDERCOUNTER



UCG105A GOURMET SERIES UNDERCOUNTER

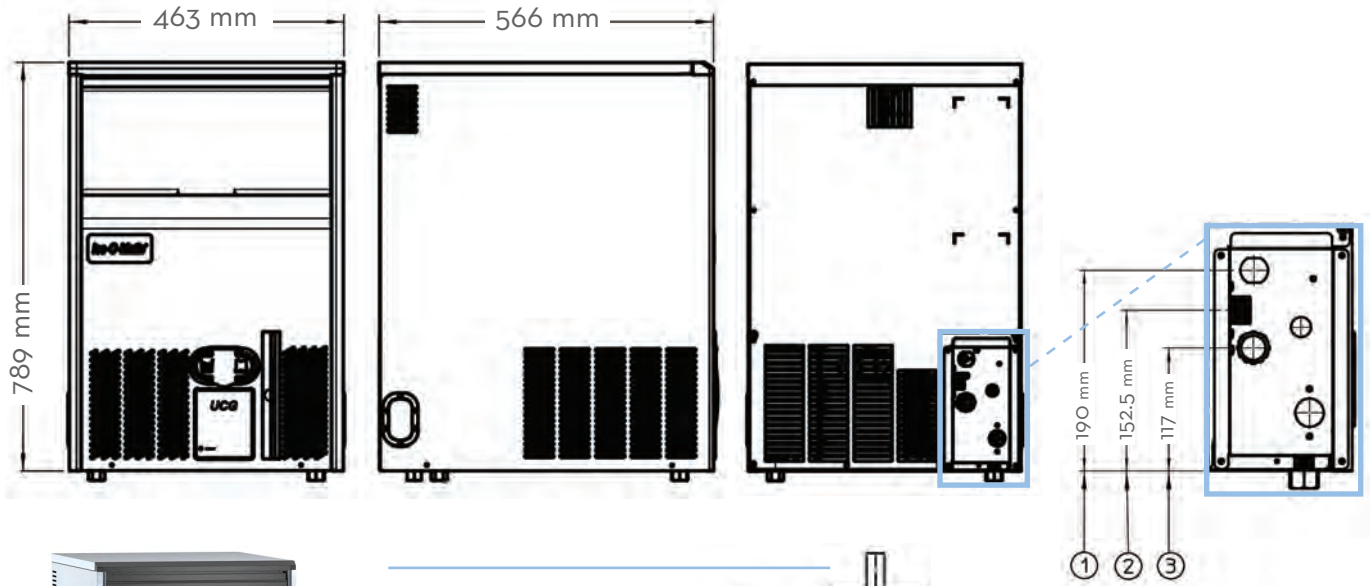

### LEGS INCLUDED

Extends from 107 mm to 150 mm



107 mm

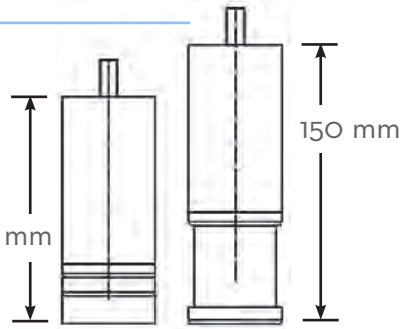

- 1 - Power Cord
- 2 - 19 mm Water Inlet
- 3 - 20 mm Water Drain

## Operating Requirements

	MINIMUM	MAXIMUM
	<b>50 Hz</b>	
Ambient Temp. Range Air	10°C	43°C
Water Temp.	5°C	38°C
Water Pressure	1 BAR	5 BAR
Electrical Voltage	230V/50Hz/1ph	

## Dimensions

ALL MODELS	
W x D x H (mm)	463 x 566 x 896-939 on legs
	839mm high on castors

## Specifications

Model Number	Cond. Unit	Ice Production per 24hrs	Ice Production per 24hrs	Ice Production per 24hrs	Storage Capacity (kg)	Water Consumption (ltr/hr)	kWH Used per 45 kg of Ice @ 32°C air/ 21°C water	Voltage Characteristics
		21°C air/10°C water (kg)	32°C air/21°C water (kg)	10°C air/10°C water (kg)				
UCG105A	Air	475	38	48	22	6	11	230/50/1

### NOTES:

Approx. Shipping Weight (kg): UCG105A (37)  
 Refrigerant Type: R134A

All specifications and performance data are subject to normal manufacturing variances.

Ice-O-Matic reserves the right to change the specifications at any time without obligation. Certifications may vary depending on country of origin.