



MFIO805 ON CIB230

### Features

- Only 21" (533 mm) wide.
- Produces up to 333 kg of ice per day.
- *SystemSafe* load monitoring system constantly checks workload on gearbox - shutting down system before a problem develops and preventing costly repairs.
- Water sensor eliminates low or no water failures and cannot be affected by adverse water conditions.
- Rugged stainless steel evaporator and auger ensures reliability.
- Industrial-grade roller bearings and heavy-duty gearbox provide years of trouble-free service.
- Made in U.S.A

### Options & Accessories

WATER FILTERS		
Ice Machine Model	Manifold	
	System	Replacement
MFIO805	CD20B	CD200B

### Ice Maker Warranty

Every Ice-O-Matic ice maker is backed by a warranty that provides both parts and labor coverage.

- Three years **Parts and Labor**.
- Five years **Parts** coverage on the compressor.

### Ice Form



FLAKED ICE

### Bin Chart *Kits for Combining Wider Bins with Smaller Models*

ICE STORAGE BINS							
Model No.	B25 110 kg 762 mm	B40 156 kg 762 mm	B42 160 kg 559 mm	B55 232 kg 762 mm	CIB230 232 kg 770 mm	B100 388 kg 1219 mm	CIB400 400 kg 1220 mm
MFIO805	Bin Adaptor Required						





## Air Cooled

Please note: air-cooled units require 152 mm clearance for air intake and exhaust.

- A. Ice maker potable water in, 3/8" FPT.
- B. Drain, 3/4" FPT.
- C. Hole for electrical connection.

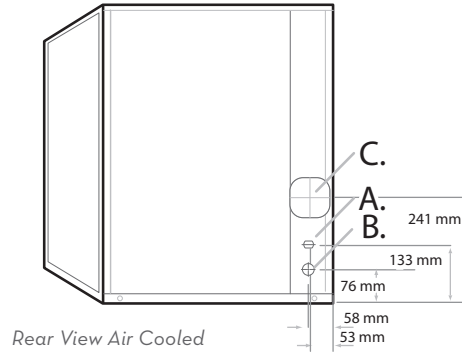
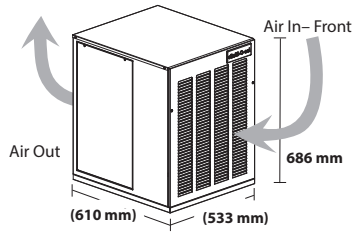

## Operating Requirements

	MINIMUM	MAXIMUM
		<b>50Hz</b>
Ambient Temp. Range Air	10°C	43°C
Water Temp.	4.4°C	32°C
Water Pressure	1.4 BAR	8.3 BAR

## Dimensions

ALL MODELS	
W x D x H (mm)	533 x 610 x 686

## Specifications

Model Number	Cond. Unit	Ice Production per 24hrs		Water Usage Litres per 45 kg of ice @ 32°C air / 21°C water	kWH Used Per 45 kg of ice @ 32°C air / 21°C water	Watts Used Per Hr @ 32°C air / 21°C water	Voltage Characteristics	Min. Circuit Ampacity	Fuse Size	Approx. BTUs per hour
		21°C air / 10°C water kg	32°C air / 21°C water kg							
MFIO805	Air	333	245	45	3.8	860	220-240/50/1	10.1	15	7,400

NOTES:  
 Number of Wires: 3 (including ground)  
 Approx. Shipping Weight kg: MFIO805A 93 kg  
 Refrigerant Type: R452A