

PROJECT	QUANTITY	ITEM NO
---------	----------	---------

Manual Low Oil Volume Open Fryer

- GVE 071** 1-well electric
- GVE 072** 2-well electric
- GVE 073** 3-well electric
- GVE 074** 4-well electric



GVE 073 3-well manual low oil volume open fryer with two full vats and one split vat

Henny Penny low oil volume open fryers use innovative design and control technology to significantly reduce frying oil consumption, extend oil life, improve fried product quality and reduce overall oil consumption and costs. Here's how:

A smaller fry vat allows the same amount of product to be cooked in 27% less oil than standard fry vats.

Built-in filtration lets you filter individual vats as needed while continuing to cook in other vats uninterrupted.

Henny Penny Low Oil Volume open fryers recover temperature very quickly for fast, consistent cooking.

Choose from 1, 2, 3, or 4-well full or split vat configurations in a slim footprint with easy-to-use programmable controls, optimal energy efficiency and durable, around-the-clock operation.

Standard Features

- Cooks the same size load in 27% less oil than standard 25 L vat
- Built-in manual filtration
 - Filter vats individually as needed
 - Rinse-wave action drains crumbs
- Heavy-duty stainless steel vats
- High-limit temperature protection
- Full vat, split vat or combination
- Heavy-duty basket rest removes easily for cleaning
- Hinged elements make vat clean-out quick and easy
- Stainless steel construction for easy-cleaning and long life
- 4 heavy-duty casters, 2 locking
- Computer control
 - 30 available cooking programs
 - Idle and melt modes
 - Load compensation
 - Proportional control
 - Filter tracking
 - Clean-out mode
 - Easy to switch language settings

Accessories shipped with unit

- Straight brush
- Gong brush
- Element lift tool
- Installation and operating manual

<input type="checkbox"/> APPROVED	<input type="checkbox"/> APPROVED AS NOTED	<input type="checkbox"/> RESUBMIT
AUTHORIZED SIGNATURE		DATE



PROJECT

ITEM NO

Manual Low Oil Volume Open Fryer

GVE 071 1-well electric
GVE 072 2-well electric
GVE 073 3-well electric
GVE 074 4-well electric

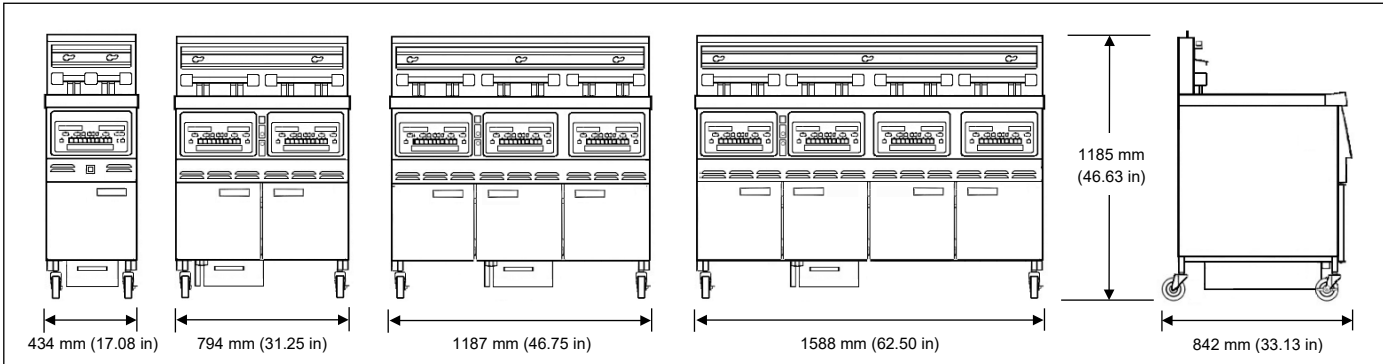

	GVE 071	GVE 072	GVE 073	GVE 074
Dimensions				
Width	434 mm (17.08 in)	794 mm (31.25 in)	1187 mm (46.75 in)	1588 mm (62.50 in)
Depth	842 mm (33.13 in)	842 mm (33.13 in)	842 mm (33.13 in)	842 mm (33.13 in)
Height	1180 mm (46.43 in)	1185 mm (46.63 in)	1185 mm (46.63 in)	1185 mm (46.63 in)
Crated				
Length	551 mm (21 in)	915 mm (36 in)	1310 mm (52 in)	1700 mm (67 in)
Depth	918 mm (36 in)	930 mm (37 in)	930 mm (37 in)	930 mm (37 in)
Height	1361 mm (54 in)	1320 mm (52 in)	1320 mm (52 in)	1320 mm (52 in)
Volume	0.7 m ³ (24 ft ³)	1.1 m ³ (40 ft ³)	1.6 m ³ (57 ft ³)	2.1 m ³ (74 ft ³)
Weight				
1 split	135 kg (298 lb)	N/A	N/A	N/A
2 full	N/A	187 kg (412 lb)	N/A	N/A
2 split	N/A	213 kg (470 lb)	N/A	N/A
3 full	N/A	N/A	247 kg (544 lb)	N/A
3 split	N/A	N/A	276 kg (607 lb)	N/A
2 full/1 split	N/A	N/A	255 kg (561 lb)	N/A
4 split	N/A	N/A	N/A	313 kg (750 lb)
Floor space	0.36 m ² (4.0 ft ²)	0.7 m ² (7.0 ft ²)	1.0 m ² (10.5 ft ²)	1.3 m ² (14.0 ft ²)

Heating immersed elements

Oil capacity

Per full vat 18.3 L or 16.5 kg (19.3 qt or 37.8 lb)
 Per split vat 9.5 L or 8.5 kg (10.0 qt or 18.7 lb)

Required clearances

Sides 51 mm (2 in) from combustible materials or other heat producing equipment; otherwise no clearance required
 Back 152 mm (6 in) air flow, connections
 Front 762 mm (30 in) remove drain pan

Electrical

Volts	Phase	Hertz	kW per vat	Amps per vat	Wire*	Cord & Plug
220/380	3	50	14.0	24.3	3NG	China EC 60309 532P6 / IP44 32 A / 250 V

Laboratory certifications



Bidding specifications

Provide Henny Penny model GVE 071, 072, 073, or 074 low oil volume electric open fryer designed to operate with 16.5 kg (37.8 lb) oil capacity per full vat. Unit may be ordered with full or split vat(s).

Unit shall incorporate:

- Built-in filtration system that filters vats individually so cooking can continue in other vats
- Oil drain pan with 4 casters and lock-in system with sensor warning when pan is not properly locked into place
- Fry vats of heavy duty stainless steel
- Computer control with programmable operation, LED digital display, idle and melt modes, load compensation, proportional control, filtration tracking, clean-out mode, multiple language settings
- 4 heavy-duty casters, 2 locking

*Units shipped without power cord and plug must have power cord and plug installed on site by a qualified electrician.

Continuing product improvement may subject specifications to change without notice.

Henny Penny Suzhou Corporation
 No. 9 Hengpu Lane, Qingqiu Avenue
 SIP, Suzhou, China (215126)

+86 512 89180268
 +86 512 89180270 Fax
www.hennypenny.com

HENNY PENNY
 Engineered to Last