



# PERFORMANCE

**INDUSTRY  
KITCHENS**

www.industrykitchens.com.au 1800 611 058

**TQ-1800H CONVEYOR TOASTER -  
up to 1200 slices per hour!**

The Hatco Toast-Qwik® 1800H is the conveyor toaster with fast, dependable and versatile toasting, offering up to 1200 slices per hour for the busiest of venues.

This powerful performer boasts adjustable upper and lower heating elements, variable speed control, Stand-by mode for power saving, and ColorGuard® technology to monitor the toasting cavity temperature to vary conveyor speed. This method allows for instant automatic adjustment of toasting time to match the bread product being toasted and eliminates the variations caused by peak and low demand times.

### Standard features

- Hatco's ColorGuard sensing system assures toast uniformity
- Power save mode with indicator light saves energy and money during slow periods
- Adjustable upper and lower heating elements for maximum control of toast quality
- Efficient design of front or rear discharge allows Toast-Qwik to be placed where it is most convenient – for sending product to operator side or customer/server
- Opening height is 76mm
- Insulation and an interior fan provide cool surface temperatures
- Toast storage area keeps bread warm and dry
- Comes with our exclusive 13 month on-site parts and labour warranty\*

\*See full terms & conditions





# Model TQ-1800H Toast-Qwik® High Output Electric Conveyor Toaster

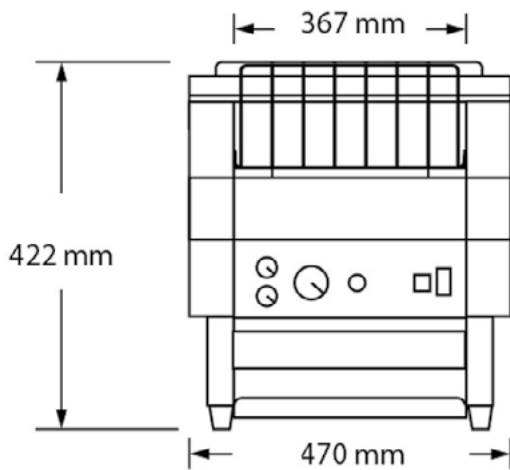

FRONT VIEW

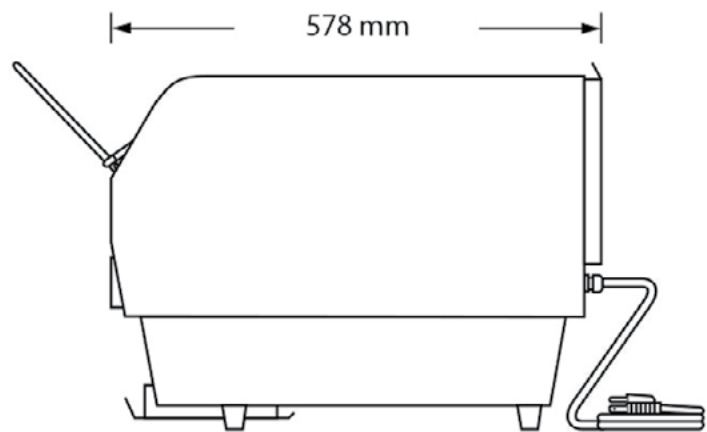

SIDE VIEW

## SPECIFICATIONS

Model	Dimensions (Width x Depth x Height)	Volts	Hertz	Phase	Watts	Amps	Ship Weight*
TQ-1800H	470 x 578 x 422 mm Tray extends 165 mm in rear	240	50	Single	4650	19.4	33 kg

\* Shipping weight includes packaging.  
Unit is supplied unplugged

**CORD LOCATION** Bottom right corner on back of unit.