



People who serve, products that solve.™

INDUSTRY KITCHENS

www.industrykitchens.com.au 1800 611 058



RHW2-1
RHW2-1 comes standard w/ one 11qt round pan and hinged lid.



RHW2-2
RHW2-2 comes standard w/ two 11qt round pans and hinged lids.



MULTIPURPOSE RHW2

RHW2-1 RHW2-2 RHW2-1B

BOIL STEAM WARM

Features

The new multipurpose HeatMax Heated Well from Hatco Corporation offers the flexibility of food warmer, soup kettle, Bain-Marie heater, steamer and pasta cooker all in one! With a range of temperature settings, HeatMax can boil pasta and soup noodles, steam dim sum, keep food warm, hold soups, curry, gravies, and toppings at safe serving temperatures. Heat is evenly distributed throughout the unit to hold foods at desired temperatures, and the insulated, stainless steel design offers easy maintenance and durable performance.



RHW2-1B (Built-In)
RHW2-1B (Built-in) with a separate control panel

Features

- Upgraded electronic thermostatic control, set temperature range from 40-95° C in Hold mode.
- Default 100° C in Heat mode.
- Countdown timer, set time from 1-360 minutes in Hold mode, 1-120 minutes in Heat mode.
- Toggle from Heat to Hold mode automatically upon countdown of timer in Heat mode.
- Actual temperature display.
- Audible alert in case of a dry pan.
- Special steam plate accessory for fast steaming and rethermalizing.
- Available in single or dual 10-liters (11-quarts) models.
- Available in free-standing or built-in models.



HEATMAX Heated Round Wells

Models RHW2-1, RHW2-2, RHW2-1B

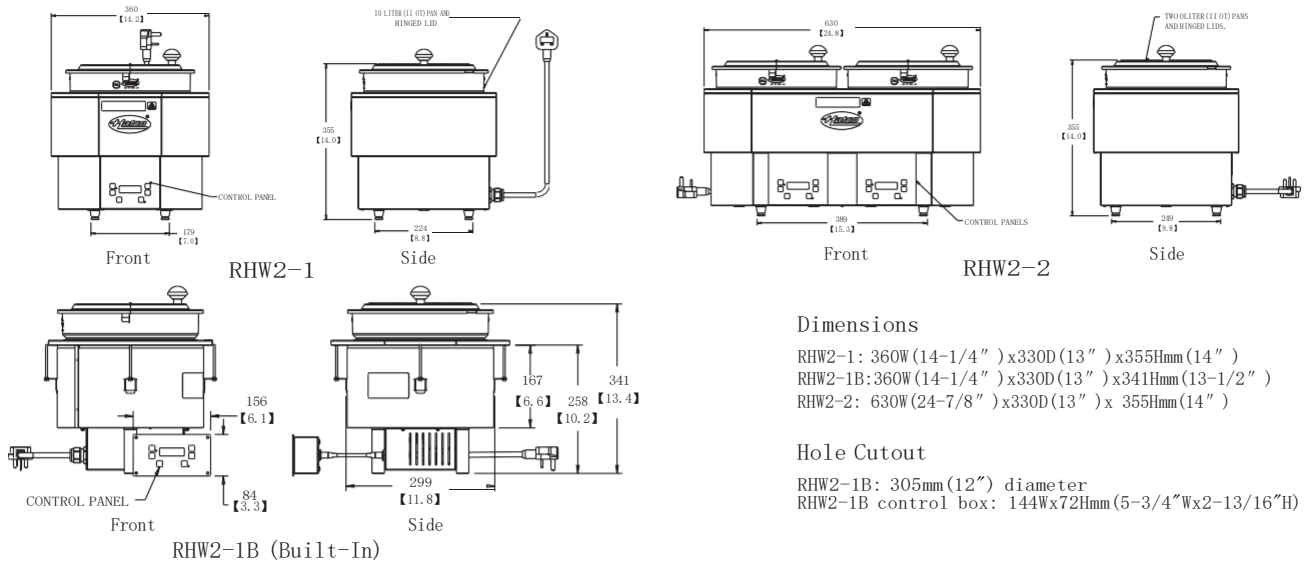

Dimensions

RHW2-1: 360W (14-1/4")x330D (13")x355Hmm (14")
 RHW2-1B: 360W (14-1/4")x330D (13")x341Hmm (13-1/2")
 RHW2-2: 630W (24-7/8")x330D (13")x 355Hmm (14")

Hole Cutout

RHW2-1B: 305mm (12") diameter
 RHW2-1B control box: 144Wx72Hmm (5-3/4"Wx2-13/16"H)

Specifications

Model	Voltage	Hertz	Phase	Power	Current	Plugs	Shipping Weight
RHW2-1	220 V	50/60 Hz	1	1145 W	5.2 A	CCC 10A, CEE 7/7 Schuko, BS-1363, AS 3112 10A	12 kg (27 lbs)
	230 V		1	1250 W	5.4 A		
	240 V		1	1360 W	5.7 A		
RHW2-1B	220 V	50/60 Hz	1	1145 W	5.2 A	CCC 10A, CEE 7/7 Schuko, BS-1363, AS 3112 10A	12 kg (28 lbs)
	230 V		1	1250 W	5.4 A		
	240 V		1	1360 W	5.7 A		
RHW2-2	220 V	50/60 Hz	1	2290 W	10.4 A	CCC 16A, CEE 7/7 Schuko, BS-1363, AS 3112 15A	14 kg (30 lbs)
	230 V		1	2500 W	10.9 A		
	240 V		1	2720 W	11.3 A		

Note: Shipping weight inclusive of packaging.

Plug Types

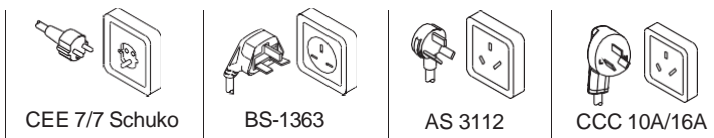

RHW2-1B

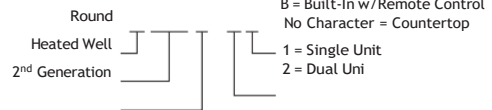

Accessories

- RHW-SP.....6 holes steam plate
- RHW-11QT-LID-HG.....10L (11 qt) hinged lid
- RHW-11QT-LID.....10L (11 qt) lid
- RHW-11QT-POT.10L (11qt) round pan 221x203mm
- RHW-11QT-POTH.10L (11 qt) round pan w/
handle 221x203mm

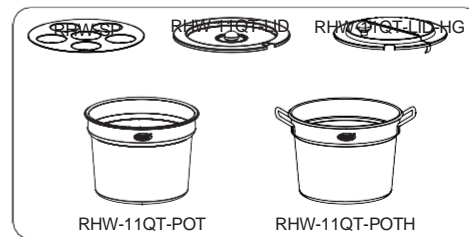

RHW2 Accessories



PRODUCT SPECS

Heated Well

The Heated Well shall be a HeatMax, manufactured by the Hatco Corporation China.

The Heated Well shall be a Heat-Max Model ..., rated at ... watts, ... volts, single phase and be ... millimeters in overall width.

The HeatMax shall include an electric heating element and be equipped with an electronic controller adjustable from 40° to 100°C (104° to 212°F).

The Heated Well shall be factory assembled ready for electrical installation. The HeatMax shall consist of a stainless steel housing. Food holding pots and pot lids shall be included.