

FFAR 0.4 - 0.6 Series

Sub Zero Flake Ice Machines

230v 1 Phase 50Hz



FFo.4AR / FFo.6AR
Includes stainless steel covers

The FFAR Series Subzero Flake Ice Machines are designed using advanced technology, with highly economical energy consumption, excellent performance and ease of operation.

The FFAR Series uses advanced computer technology to control the ice making process. The PC board controls and monitors the functionality of the ice machine, allowing for easy diagnosis of any problems that may occur.

Ice is produced at -9 degrees, from a static vertical evaporator, completely sealed, with minimum maintenance required for the lifetime of the machine. The complete evaporator, base and control panel are made from high quality, 304 Stainless Steel.

The FFAR Series Flake Ice Machines can be fitted on a wide range of storage options depending on the customer's requirements.

The FFAR Series is extremely versatile and is used in a wide variety of applications, including: Seafood, Meat Processing, Poultry, Supermarkets and Mining.

Warranty: 3 years parts and labour, 5 years on evaporator assembly.

ACCESSORIES

WATER FILTERS	
SYSTEM	REPLACEMENT
CD40B	CD2020B CD250B

ICE PRODUCTION

Model Number	Ice Production Per 24hrs
FFo.4AR	400 kg
FFo.6AR	600 kg

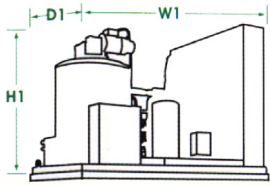

OUTSIDE DIMENSIONS

Model	Ice Machine Dimensions W1	Ice Machine Dimensions D1	Ice Machine Dimensions H1
FFo.4AR	1090 mm	700 mm	745 mm
FFo.6AR	1250 mm	750 mm	840 mm

Includes stainless steel covers

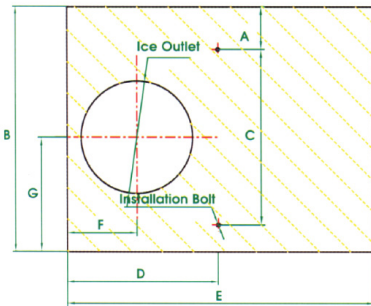
ICE OUTLET DIMENSIONS

Model	A	B	C	D	E	F	G	Ice Outlet Internal Dia.
FFo.4AR	87 mm	700 mm	395 ± 1 mm	432.5 mm	1090 mm	216.5 mm	447 mm	Ø 326
FFo.6AR	95 mm	750 mm	450 ± 1 mm	585 mm	1250 mm	419 mm	430 mm	Ø 326

TECHNICAL PARAMETER

Model	Condenser	Power	Current Draw	Water Consumption	Inlet Water Connection	Drainpipe External Diameter	Net Weight (kg)
FFo.4AR	Air Cooled	1.7 kW	3.7 A	13L/hr	3/4" GAS	Ø 21 mm	180
FFo.6AR	Air Cooled	3 kW	6.4 A	21L/hr	3/4" GAS	Ø 21 mm	220

Notes:

- Refrigerant Type: R404A
- Standard Conditions: Ambient Air Temperature 25°C, Water Temperature 16°C
- Electrical Voltage: 380V/50Hz / 3N
- Supply Water Pressure: 1.5 BAR - 5 BAR

