



CTX DZ55T

Infrared Conveyor Oven



PRINCIPLE

The CTX delivers perfection time and time again. The automated cooking platform is designed to cook, bake, broil, sear, steam, or sous vide in high-volume kitchens. The versatile CTX could be the only piece of equipment needed in the kitchen. Not only can the CTX cooking platform eliminate remakes and meal comps, but cooking consistency is matched with faster bake times than any traditional cooking equipment at up to 60% faster for some menu items. Help keep labor cost down with the CTX automated cooking platform, as customers using the oven reported 3,300 kitchen labor hours eliminated per year.

STANDARD FEATURES

- 18-gauge stainless steel exterior
- Fully insulated on all sides
- Top and bottom infrared emitters evenly heat (two on top and two on bottom)
- “Cool Skin” safety feature keeps the external surface of the oven under 120°F
- Quiet operation
- Independently-controlled microprocessor with time/date clock, standby mode, and self-cleaning cycle
- The operator can preset up to 15 different time and temperature combinations
- Stackable up to three high
- For installation under a ventilation hood
- One-year parts and labor warranty – includes start-up and demonstrations (U.S. only)

OPTIONAL FEATURES

- Split belt with individually-adjustable speed settings
- Exit trays (various lengths)

CERTIFICATIONS



Middleby Marshall reserves the right to make substitutions of components or change specifications without prior notice.

CTX DZ55T

Infrared Conveyor Oven

DIMENSIONS

Single Units

Heating Zone	55.22"	1403 mm
Baking Area	6.9ft ²	0.64 m ²
Belt Length	81"	2057 mm
Overall Length	82.98"	2108 mm
Belt Width (Single)	18"	457 mm
Belt Width (50/50)	9" / 9"	229 mm / 229 mm
Height with 4" (102 mm) legs	28.45"	723 mm
Height with 15" (381 mm) legs	39.45"	1002 mm
Depth	39.03"	991 mm

Double Stacked Units

Heating Zone	110.44"	2805 mm
Baking Area	13.8 ft ²	1.28 m ²
Belt Length	81"	2057 mm
Overall Length	82.98"	2108 mm
Belt Width (Single)	18"	457 mm
Belt Width (50/50)	9" / 9"	229 mm / 229 mm
Height with 15" (381 mm) legs	55.24"	1403 mm
Depth	39.03"	991 mm

Triple Stacked Units

Heating Zone	165.66"	4208 mm
Baking Area	20.7 ft ²	1.92 m ²
Belt Length	81"	2057 mm
Overall Length	82.98"	2108 mm
Belt Width (Single)	18"	457 mm
Belt Width (50/50)	9" / 9"	229 mm / 229 mm
Height with Casters	65.13"	1654 mm
Depth	39.03"	991 mm

Quad Stacked Units

Heating Zone	220.88"	5610 mm
Baking Area	27.6 ft ²	2.56 m ²
Belt Length	81"	2057 mm
Overall Length	82.98"	2108 mm
Belt Width (Single)	18"	457 mm
Belt Width (50/50)	9" / 9"	229 mm / 229 mm
Height with Casters	71.96"	1828 mm
Depth	39.03"	991 mm

GENERAL SPECIFICATIONS

Wall Clearance

Rear of Conveyor to Wall	0"	0 mm
Right Side	4"	102 mm
Left Side	4"	102 mm
Bake Operating Temperature	200°F-900°F	93°C-482°C
Time Range	1-60 minutes	

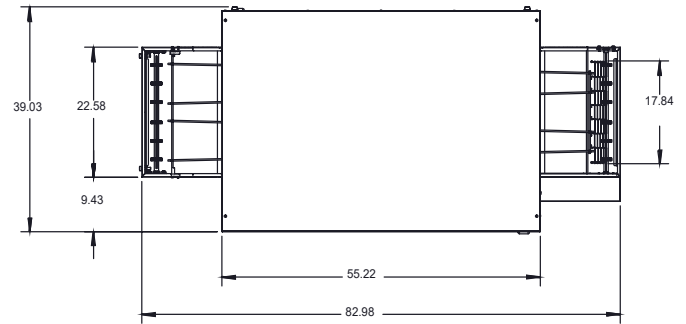

Top View

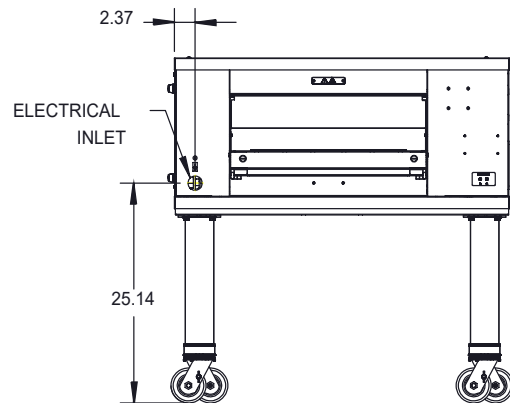

Side View with 15" Legs

CTX DZ55T

Infrared Conveyor Oven

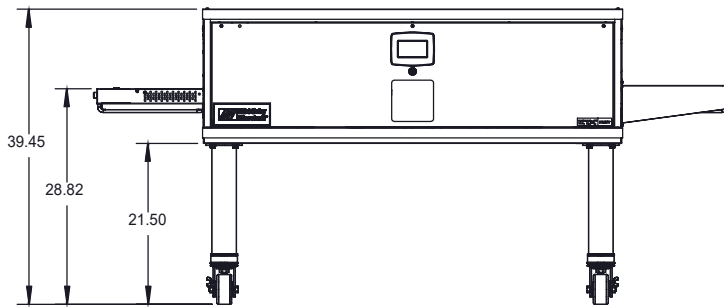

Front View with 15" Legs

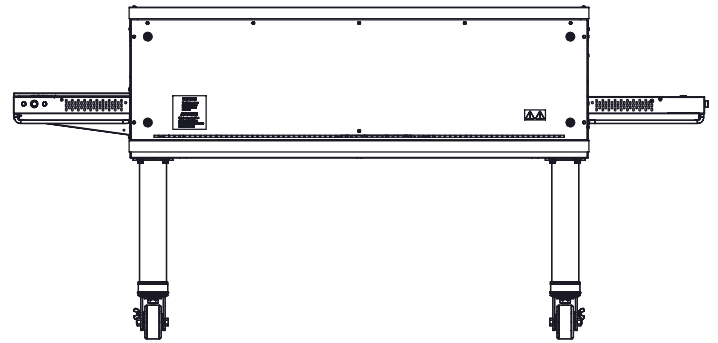

Rear View with 15" Legs

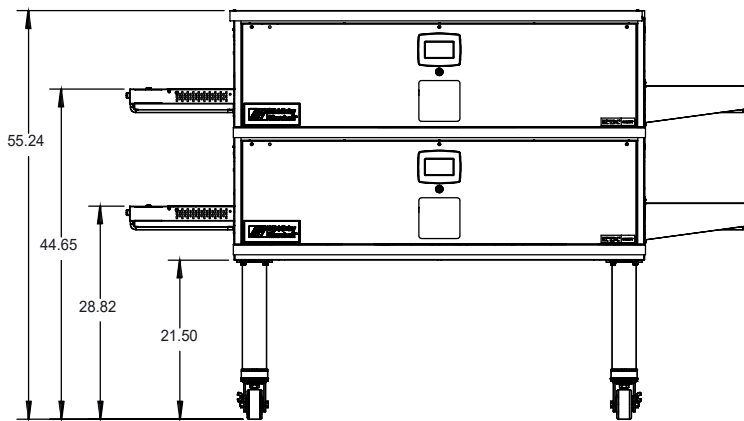

Front View – Double Stacked with 15" Legs

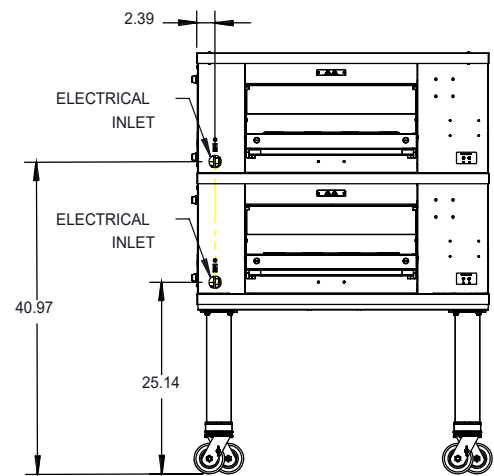

Side View – Double Stacked with 15" Legs

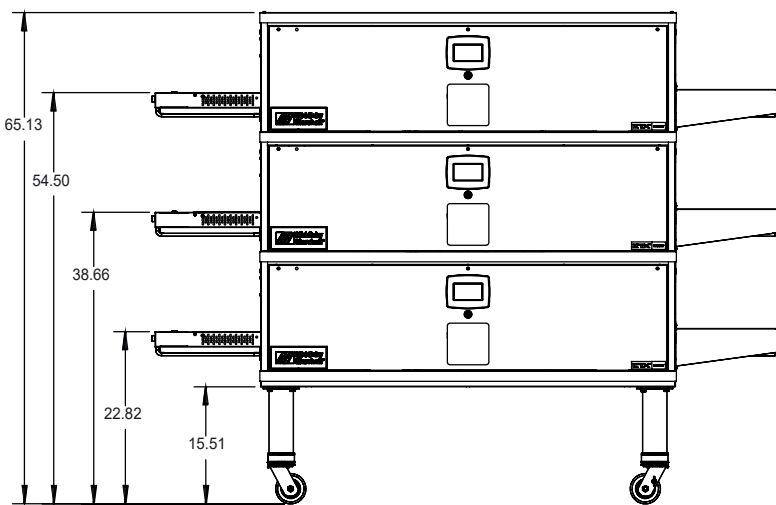

Front View – Triple Stacked with Casters

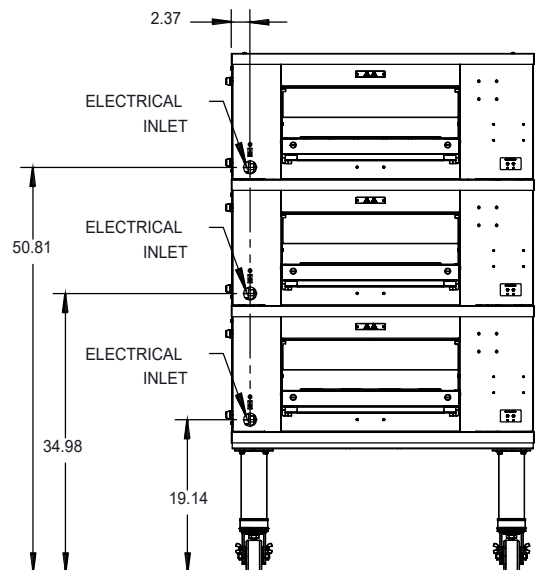

Side View – Triple Stacked with Casters

CTX DZ55T

Infrared Conveyor Oven

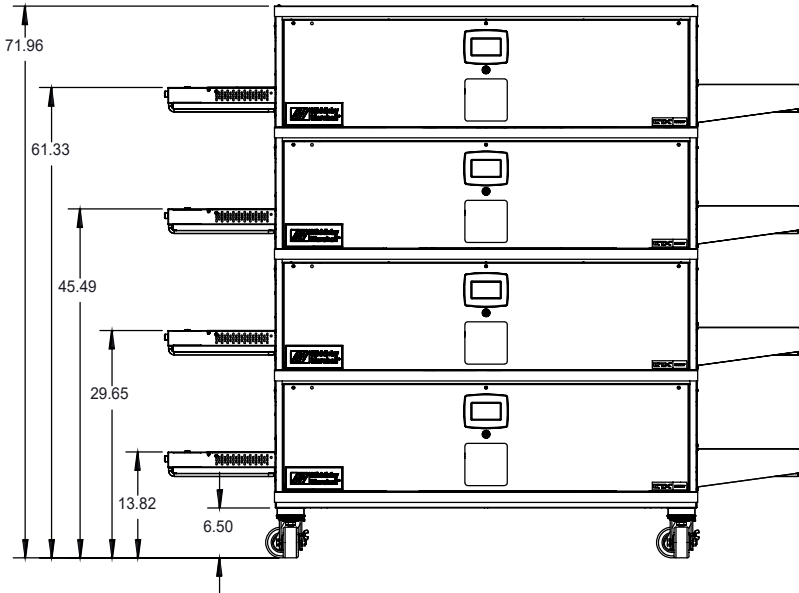

Front View – Quad Stacked with Casters

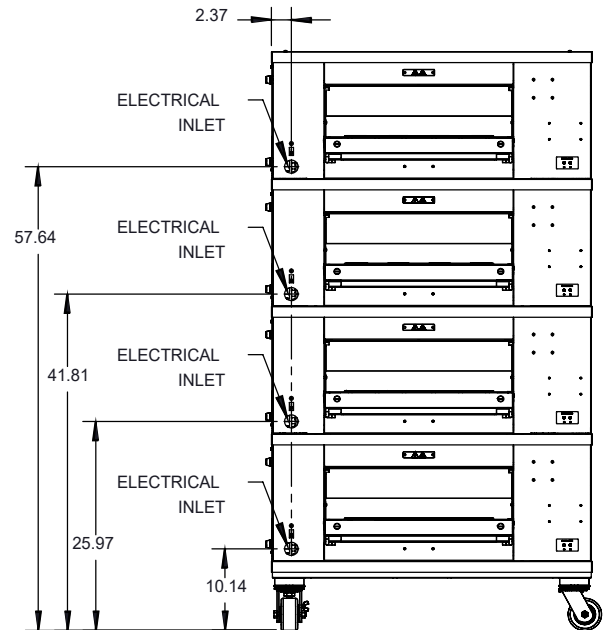

Side View – Quad Stacked with Casters

Electrical Specification

VOLTAGE	PHASE	FREQUENCY	RATED HEAT INPUT	AVG OPERATING	AMPERAGE*				SUPPLY	BREAKERS
					L1	L2	L3	N		
208 V*	1**	50/60 Hz	7.7 kW	4.7 kW	32.0	32.0	-	-	3-wire (2L+G)	35 A*
208 V*	3	50/60 Hz	7.5 kW	4.7 kW	26.0	26.0	19.0	-	4-wire (3L+G)	30 A*
240 V*	1**	50/60 Hz	7.6 kW	5.0 kW	28.0	28.0	-	-	3-wire (2L+G)	30 A*
240 V*	3	50/60 Hz	7.9 kW	5.0 kW	23.0	23.0	17.0	-	4-wire (3L+G)	25 A*
380 V CE	3	50/60 Hz	6.7 kW	5.0 kW	18.0	9.0	9.0	9.0	5-wire (3L+N+G)	25 A
230 V CE	1	50/60 Hz	7.0 kW	5.0 kW	22.0	22.0	-	-	3-wire (2L+G)	30 A

* U.S. Domestic Ovens: a 6' cord and NEMA L15-30P plug are standard. A NEMA L15-30R receptacle is also available as an option. Canada and others require a breaker 5 amps greater than the breaker size shown.
** Units are built and shipped three phase and can be field converted to single phase. The cord and plug for the single phase application is user supplied.