



**Middleby  
Marshall®**

**INDUSTRY  
KITCHENS**  
www.industrykitchens.com.au 1800 611 058

# CTX DZ33T

Infrared Conveyor Oven



## PRINCIPLE

The CTX delivers perfection time and time again. The automated cooking platform is designed to cook, bake, broil, sear, steam, or sous vide in high-volume kitchens. The versatile CTX could be the only piece of equipment needed in the kitchen. Not only can the CTX cooking platform eliminate remakes and meal comps, but cooking consistency is matched with faster bake times than any traditional cooking equipment at up to 60% faster for some menu items. Help keep labor cost down with the CTX automated cooking platform, as customers using the oven reported 3,300 kitchen labor hours eliminated per year.

## STANDARD FEATURES

- 18-gauge stainless steel exterior
- Fully insulated on all sides
- Top and bottom infrared emitters evenly heat (two on top and two on bottom)
- “Cool Skin” safety feature keeps the external surface of the oven under 120°F
- Quiet operation
- Independently-controlled microprocessor with time/date clock, standby mode, and self-cleaning cycle
- The operator can preset up to 15 different time and temperature combinations
- Stackable up to three high
- For installation under a ventilation hood
- One-year parts and labor warranty – includes start-up and demonstrations (U.S. only)

## OPTIONAL FEATURES

- Split belt with individually-adjustable speed settings
- Exit trays (various lengths)

## CERTIFICATIONS



Middleby Marshall reserves the right to make substitutions of components or change specifications without prior notice.

# CTX DZ33T

## Infrared Conveyor Oven

### DIMENSIONS

#### Single Units

Heating Zone	31.22"	793 mm
Baking Area	3.9 ft <sup>2</sup>	0.36 m <sup>2</sup>
Belt Length	56.25"	1429 mm
Overall Length	59.02"	1499 mm
Belt Width (Single)	18"	457 mm
Belt Width (50/50)	9" / 9"	229 mm / 229 mm
Height with 4" (102 mm) legs	21.88"	556 mm
Height with 15" (381 mm) legs	39.46"	1002 mm
Depth	39.03"	991 mm

#### Double Stacked Units

Heating Zone	62.44"	1586 mm
Baking Area	7.8 ft <sup>2</sup>	0.72 m <sup>2</sup>
Belt Length	56.25"	1429 mm
Overall Length	59.02"	1499 mm
Belt Width (Single)	18"	457 mm
Belt Width (50/50)	9" / 9"	229 mm / 229 mm
Height with 15" (381 mm) legs	55.32"	1405 mm
Depth	39.03"	991 mm

#### Triple Stacked Units

Heating Zone	93.66"	2379 mm
Baking Area	11.7 ft <sup>2</sup>	1.1 m <sup>2</sup>
Belt Length	56.25"	1429 mm
Overall Length	59.02"	1499 mm
Belt Width (Single)	18"	457 mm
Belt Width (50/50)	9" / 9"	229 mm / 229 mm
Height with Casters	65.18"	1656 mm
Depth	39.03"	991 mm

#### Quad Stacked Units

Heating Zone	124.88"	3172 mm
Baking Area	15.6 ft <sup>2</sup>	1.4 m <sup>2</sup>
Belt Length	56.25"	1429 mm
Overall Length	59.02"	1499 mm
Belt Width (Single)	18"	457 mm
Belt Width (50/50)	9" / 9"	229 mm / 229 mm
Height with Casters	72.02"	1829 mm
Depth	39.03"	991 mm

### GENERAL SPECIFICATIONS

#### Wall Clearance

Rear of Conveyor to Wall	0"	0 mm
Right Side	4"	102 mm
Left Side	4"	102 mm
Bake Operating Temperature	200°F-900°F	93°C-482°C
Time Range	1-60 minutes	

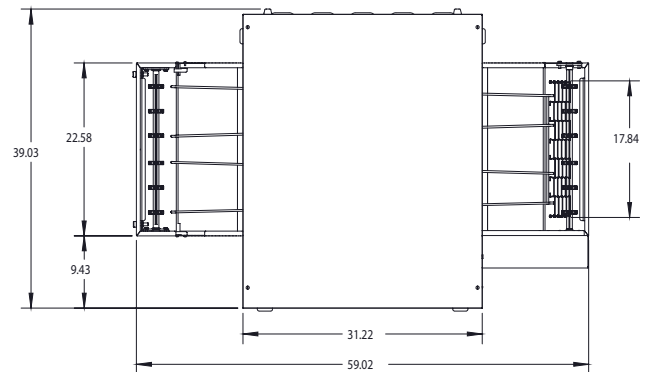

Top View

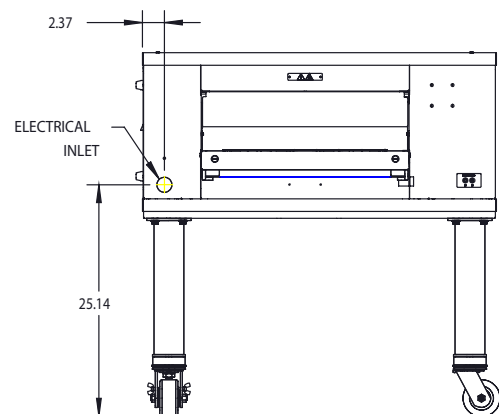

Side View with 15" Legs

# CTX DZ33T

Infrared Conveyor Oven

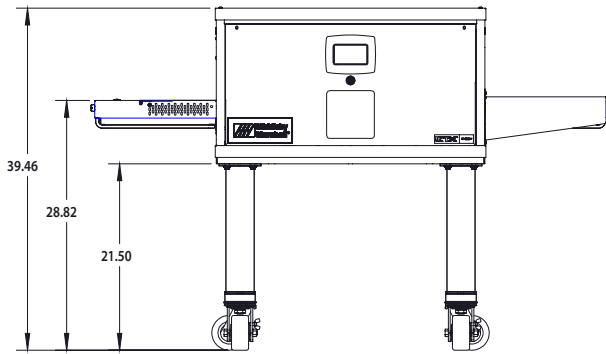

Front View with 15" Legs

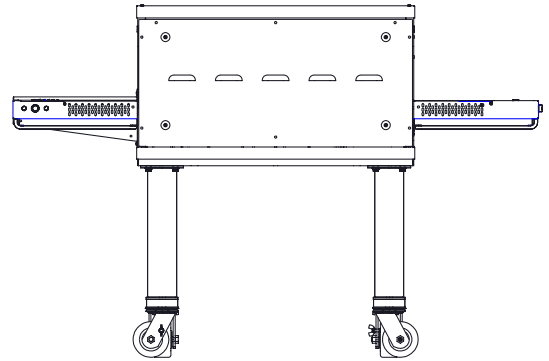

Rear View with 15" Legs

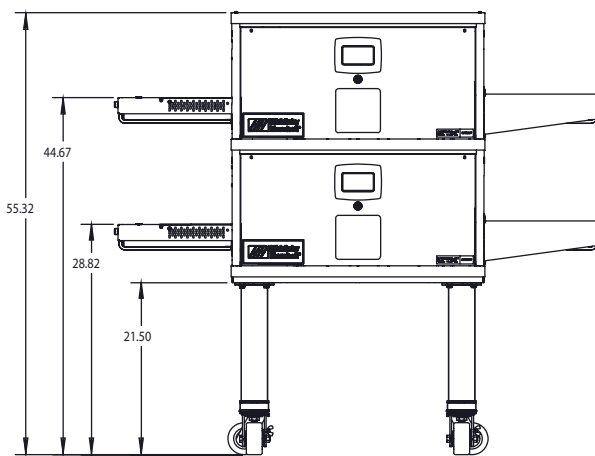

Front View – Double Stacked with 15" Legs

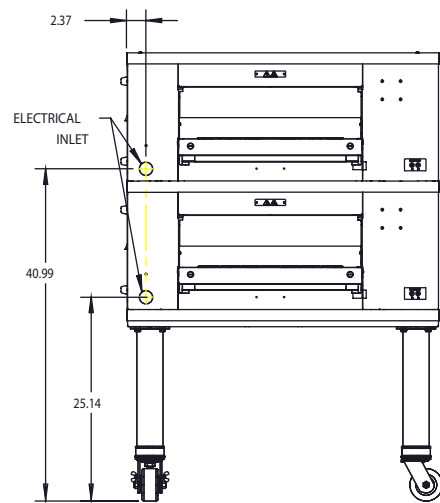

Side View – Double Stacked with 15" Legs

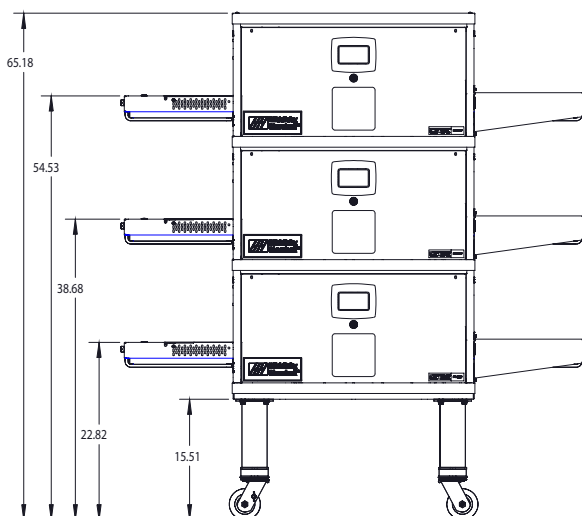

Front View – Triple Stacked with Casters

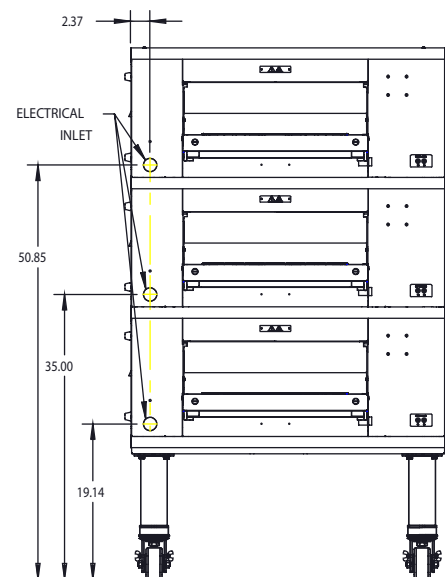

Side View – Triple Stacked with Casters

# CTX DZ33T

Infrared Conveyor Oven

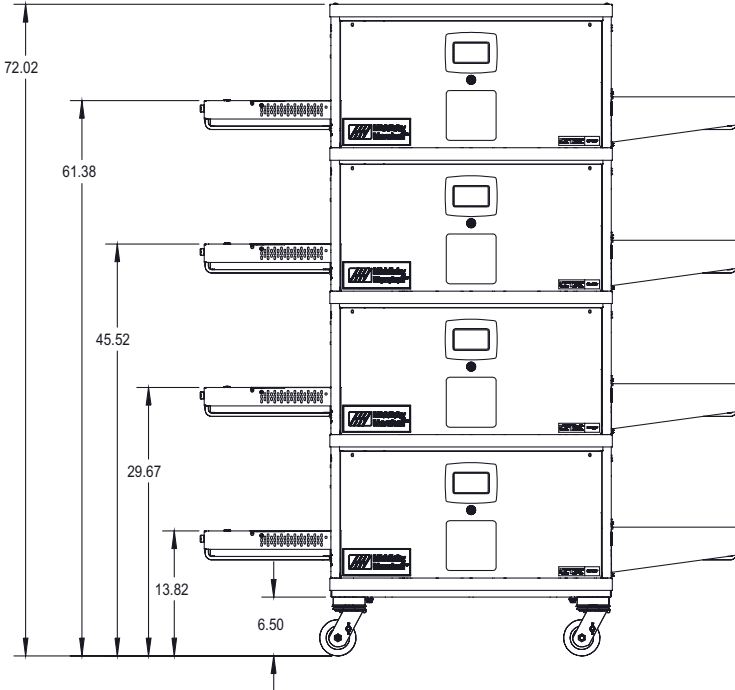

Front View – Quad Stacked with Casters

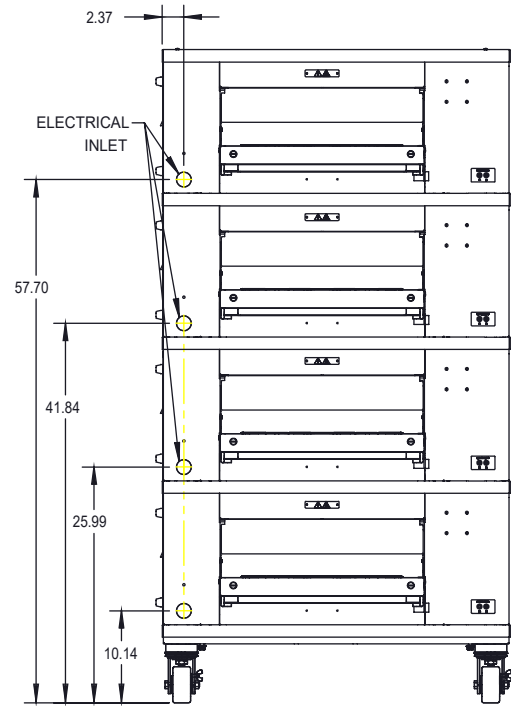

Side View – Quad Stacked with Casters

## Electrical Specification

VOLTAGE	PHASE	FREQUENCY	RATED HEAT INPUT	AVG OPERATING	AMPERAGE*				SUPPLY	BREAKERS
					L1	L2	L3	N		
208 V*	1**	50/60 Hz	7,7 kW	4.7 kW	32.0	32.0	-	-	3-wire (2L+G)	35 A*
208 V*	3	50/60 Hz	7.5 kW	4.7 kW	26.0	26.0	19.0	-	4-wire (3L+G)	30 A*
240 V*	1**	50/60 Hz	7.6 kW	5.0 kW	28.0	28.0	-	-	3-wire (2L+G)	30 A*
240 V*	3	50/60 Hz	7.9 kW	5.0 kW	23.0	23.0	17.0	-	4-wire (3L+G)	25 A*
380 V CE	3	50/60 Hz	6.7 kW	5.0 kW	18.0	9.0	9.0	9.0	5-wire (3L+N+G)	25 A
230 V CE	1	50/60 Hz	7.0 kW	5.0 kW	22.0	22.0	-	-	3-wire (2L+G)	30 A

\* U.S. Domestic Ovens: a 6' cord and NEMA L15-30P plug are standard. A NEMA L15-30R receptacle is also available as an option. Canada and others require a breaker 5 amps greater than the breaker size shown.  
 \*\* Units are built and shipped three phase and can be field converted to single phase. The cord and plug for the single phase application is user supplied.