



**Middleby  
Marshall®**

**INDUSTRY  
KITCHENS**  
www.industrykitchens.com.au 1800 611 058

# CTX DZ26T

Infrared Conveyor Oven



## PRINCIPLE

The CTX delivers perfection time and time again. The automated cooking platform is designed to cook, bake, broil, sear, steam, or sous vide in high-volume kitchens. The versatile CTX could be the only piece of equipment needed in the kitchen. Not only can the CTX Grilling System eliminate remakes and meal comps, but cooking consistency is matched with faster bake times than any traditional cooking equipment at up to 60% faster for some menu items. Help keep labor cost down with the CTX Grilling System, as customers using the oven reported 3,300 kitchen labor hours eliminated per year.

## STANDARD FEATURES

- 18-gauge stainless steel exterior
- Fully insulated on all sides
- Top and bottom infrared emitters evenly heat (two on top and two on bottom)
- “Cool Skin” safety feature keeps the external surface of the oven under 120°F
- Quiet operation
- Independently-controlled microprocessor with time/date clock, standby mode, and self-cleaning cycle
- Patented MenuSelect® feature allows the operator to preset up to 15 different time and temperature combinations
- Stackable up to three high
- For installation under a ventilation hood
- One-year parts and labor warranty – includes start-up and demonstrations (U.S. only)

## OPTIONAL FEATURES

- Split belt with individually-adjustable speed settings
- Exit trays (various lengths)

## CERTIFICATIONS



Middleby Marshall reserves the right to make substitutions of components or change specifications without prior notice.

# CTX DZ26T

## Infrared Conveyor Oven

### GENERAL SPECIFICATIONS

Wall Clearance		
Rear of Conveyor to Wall	0"	0 mm
Right Side	4"	102 mm
Left Side	4"	102 mm
Bake Operating Temperature	200°F-900°F	93°C-482°C
Time Range	1-60 minutes	

### DIMENSIONS

Single Units		
Heating Zone	26"	660 mm
Baking Area	2.9 ft <sup>2</sup>	0.27 m <sup>2</sup>
Belt Length	42.16"	1071 mm
Overall Length	45.84"	1164 mm
Belt Width (Single)	16"	406 mm
Belt Width (50/50)	7.5" / 7.5"	191 mm / 191 mm
Height with 4" (102 mm) legs	21.88"	556 mm
Height with 15" (381 mm) legs	39.38"	1000 mm
Depth	29.06"	738 mm
Double Stacked Units		
Heating Zone	26"	660 mm
Baking Area	5.8 ft <sup>2</sup>	0.5 m <sup>2</sup>
Belt Length	42.16"	1071 mm
Overall Length	45.84"	1164 mm
Belt Width (Single)	16"	406 mm
Belt Width (50/50)	7.5" / 7.5"	191 mm / 191 mm
Height with 15" (381 mm) legs	55.16"	1401 mm
Depth	29.06"	738 mm
Triple Stacked Units		
Heating Zone	26"	660 mm
Baking Area	8.7 ft <sup>2</sup>	0.81 m <sup>2</sup>
Belt Length	42.16"	1071 mm
Overall Length	45.84"	1164 mm
Belt Width (Single)	16"	406 mm
Belt Width (50/50)	7.5" / 7.5"	191 mm / 191 mm
Height with Casters	55.93"	1950 mm
Depth	29.06"	738 mm

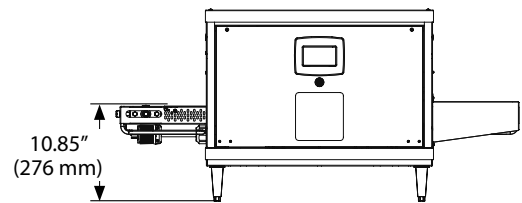
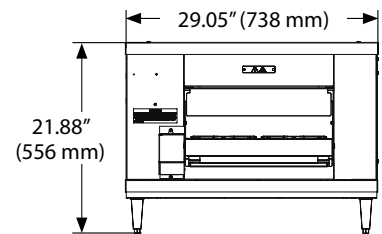
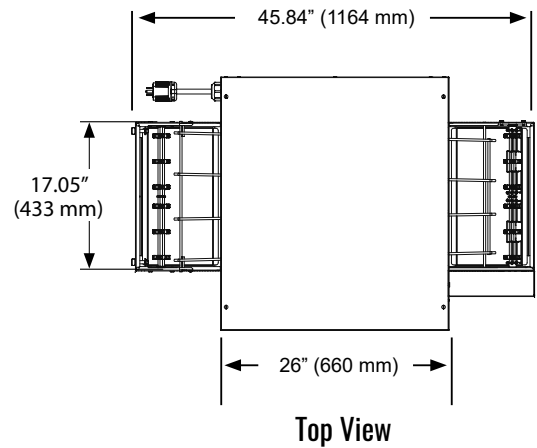

**Front View with 4" Legs**

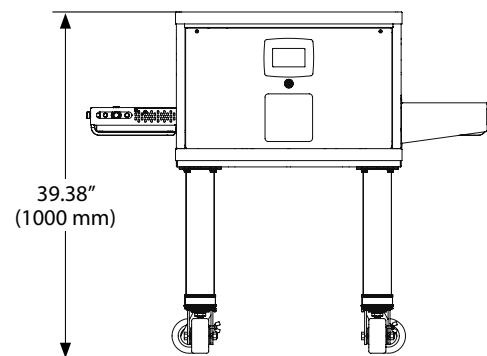

**Front View with 15" Legs**

# CTX DZ26T

## Infrared Conveyor Oven

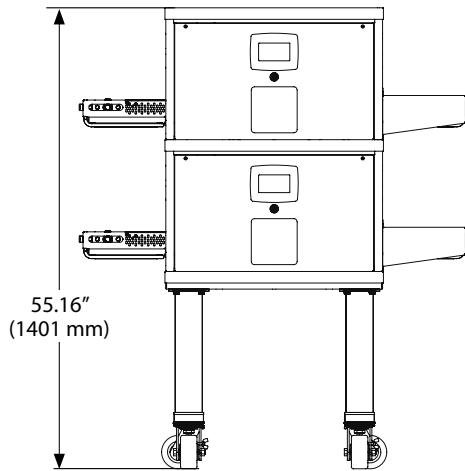

Front View – Double Stacked with 15” Legs

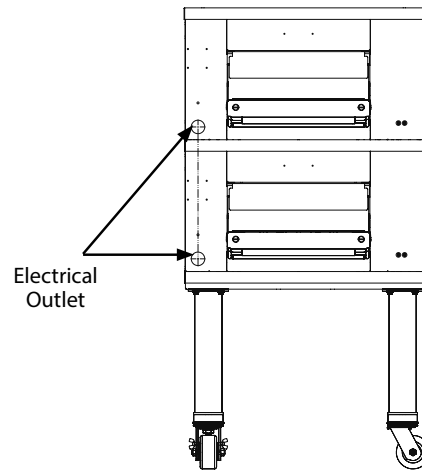

Back View – Double Stacked with 15” Legs

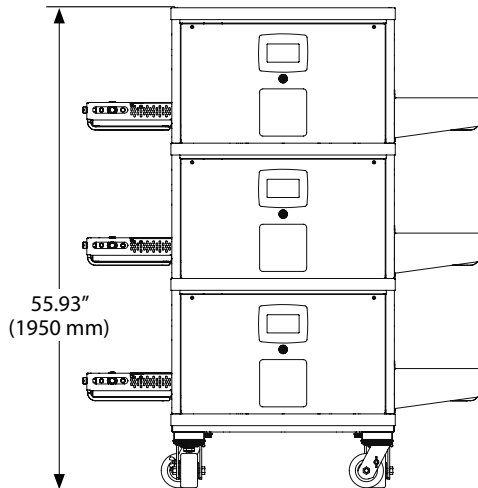

Front View – Triple Stacked with Casters

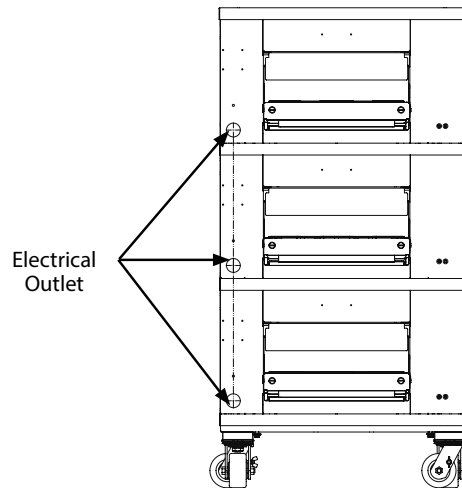

Back View – Triple Stacked with Casters

VOLTAGE	PHASE	FREQUENCY	RATED HEAT INPUT	AVG OPERATING	AMPERAGE*				SUPPLY	BREAKERS
					L1	L2	L3	N		
208 V*	1**	50/60 Hz	8 kW	4.3 kW	38.5	38.5	-	-	3-wire (2L+G)	40 A*
208 V*	3	50/60 Hz	8 kW	4.3 kW	25.4	25.4	16.6	-	4-wire (3L+G)	30 A*
240 V*	1**	50/60 Hz	8 kW	4.3 kW	33.3	33.3	-	-	3-wire (2L+G)	35 A*
240 V*	3	50/60 Hz	8 kW	4.3 kW	22.1	22.1	14.4	-	4-wire (3L+G)	25 A*
380V	3	50/60 Hz	6.7 kW	4.3 kW	15.3	7.7	7.7	7.7	5-wire (3L+N+G)	20 A
230 V CE	1**	50/60 Hz	7.3 kW	4.3 kW	32.0	32.0	-	-	3-wire (2L+G)	40 A
380 V CE	3	50/60 Hz	6.7 kW	4.3 kW	15.3	7.7	7.7	7.7	5-wire (3L+N+G)	20 A

\* U.S. Domestic Ovens: a 6' cord and NEMA L15-30P plug are optional. A NEMA L15-30R receptacle is also available as an option. Canada and others require a breaker 5 amps greater than the breaker size shown.  
\*\* Units are built and shipped three phase and can be field converted to single phase. The cord and plug for the single phase application is user supplied.