

GM0690LB

INDUSTRY
KITCHENS

www.industrykitchens.com.au 1800 611 058

BROMIC[®]
REFRIGERATION

Upright Display Fridge 659L - 1 Door - Flat Glass - Lightbox

| Vertical Display & Storage

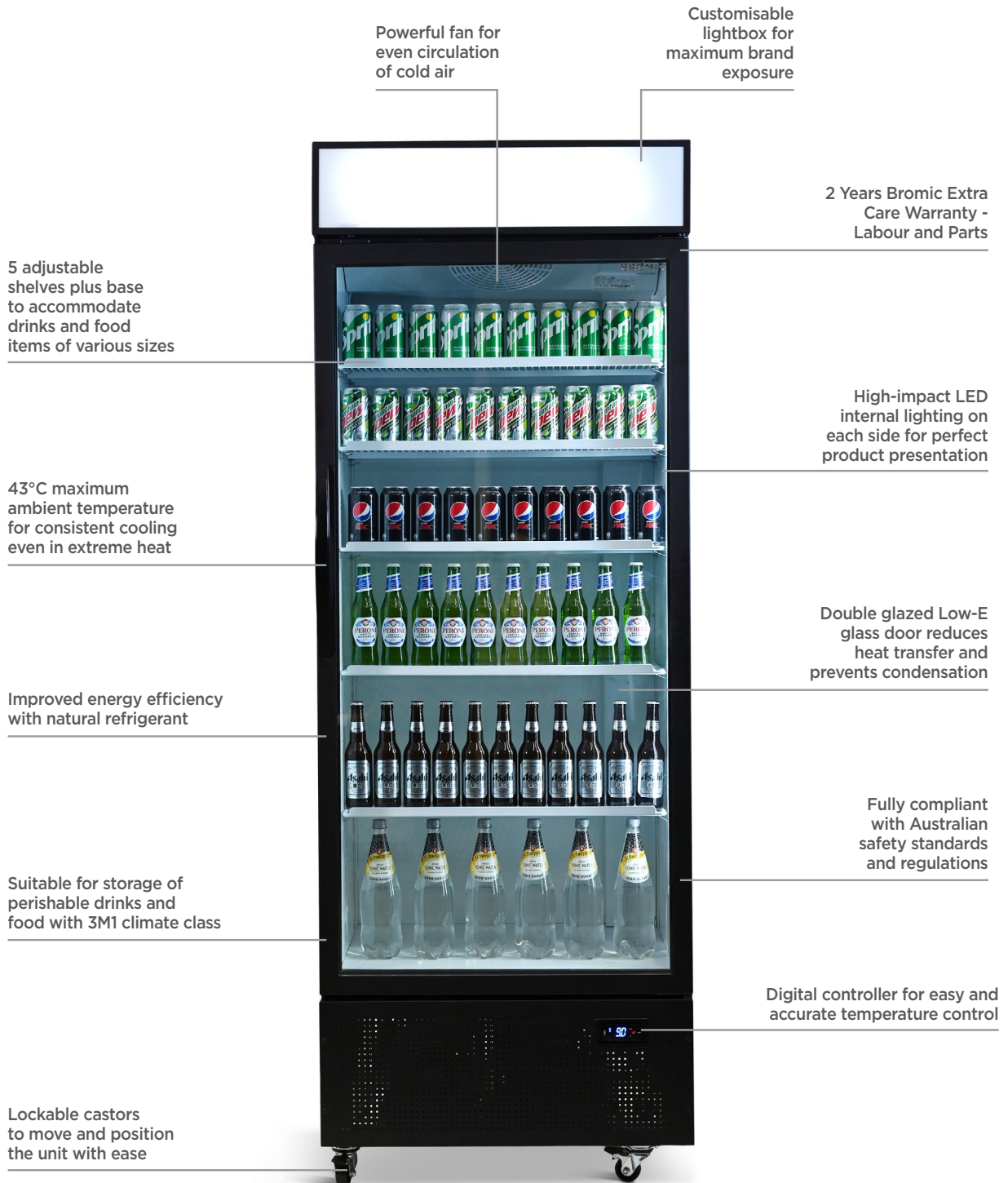

Upright Display Fridge 659L - 1 Door - Flat Glass - Lightbox

| Vertical Display & Storage

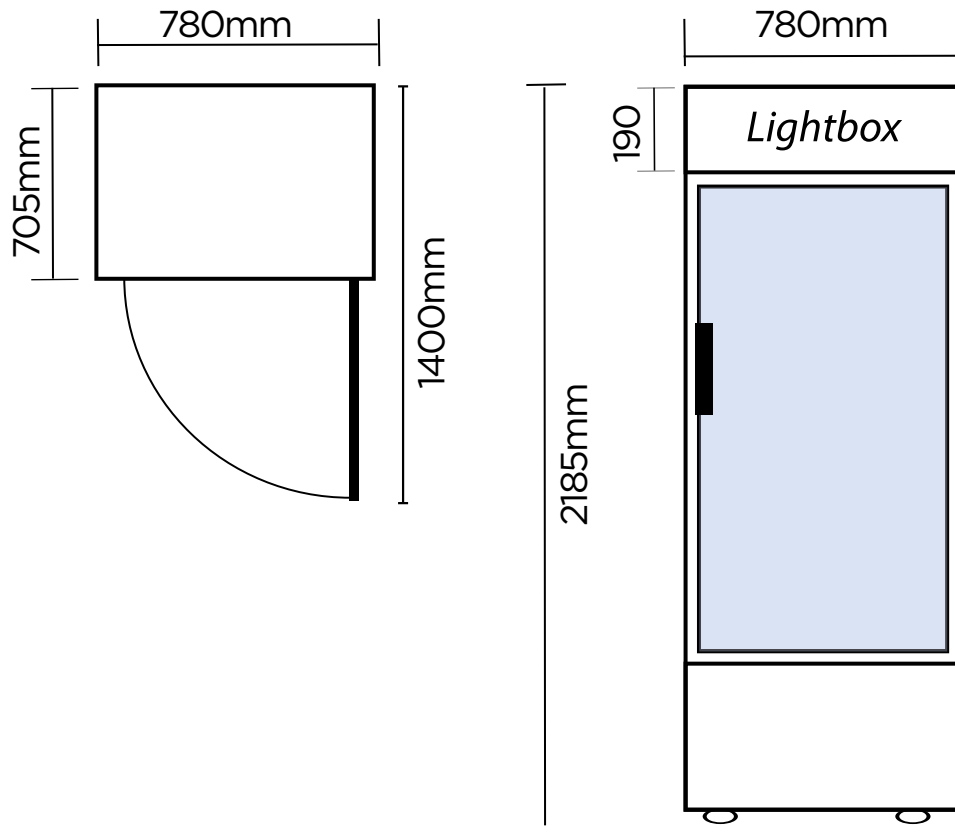

SPECIFICATIONS				DIMENSIONS	
Model Number	GM0690LB	Colour	Black	External (mm)	
Part Number	3736222	Display Light Box	Yes	Width	780
Volume	659L	Internal Light	LED	Depth	705
Unit Weight	123kg	No. of Doors	1	Height	2185
Packaged Weight	128kg	Door Type	Glass	Internal (mm)	
Adjustable Temp. Range	+1°C to +5°C	Door Glass Type	Double glazed Low-E Glass + Argon Gas	Width	702
Max. Ambient Temp.	43°C	Door Style	Hinged	Depth	555
Climate Class	3M1	Door Shape	Flat	Height	1682
Energy Consumption	3.995kWh/24h	Door Swing Dimension	695mm	Packaged (mm)	
GEMS Star Rating	7 stars	Total Depth of door open	1400mm	Width	870
Refrigeration Capacity	485W	Self-Closing Door	Yes	Depth	750
Air Circulation	Fan Forced	Door Lock	No	Height	2200
Refrigerant	R290	No. of Shelves incl Base	6		
Rated Current	3.8A	Shelf Type	Adjustable		
Electrical Voltage	220-240V	Shelves Dimensions	680(w) x 480(d) mm		
Frequency	50Hz	Temp. Controller	Digital		
Power Supply	Single Phase	Castors	Yes		
Power Plug	1 x 10A	Warranty	2 Years Bromic Extra Care Warranty - Labour and Parts		
Plug Location	Rear, Bottom right				