

INSTINCT INDUCTION COUNTERTOP GRIDDLE 10KW

Garland Instinct Countertop 10kw Induction chrome griddle has two cooking zones, 12 power levels with thermostat temperature control from 50°C to 230°C and a timer function. It is especially energy efficient and is operated using an easy to operate "Tip and Turn" control knob. The appliance is convenient and operationally reliable and its very short heating times are impressive from 20 -200° C in 3:30.

Features patented Realtime Temperature Control System with 3 sensors for fastest, safest, most precise and best pan acceptance. Large cooking zone of 618 x 577mm

STANDARD FEATURES

- Significantly reduced energy consumption thanks to high-efficiency induction technology with optimised energy transfer between the griddle and the food product
- Specially developed induction griddle with HPCR stainless steel surface protection
- Contactless multi-point temperature measurement and temperature control accurate to one degree over the entire cooking time and the entire cooking surface for optimal frying results thanks to RTCSmp technology.
- Convenient frying without heating up the surroundings thanks to direct heat transfer from the griddle to the food product by means of induction
- Especially high operational safety and reliability due to numerous protective features
- Short heat-up time from 20 – 200°C in 3 ½ minutes
- Easy to clean thanks to a removable, washable and reusable air filter
- Exceptionally robust developed for continuous restaurant operation
- Height adjustable locking feet. Spatter guard. Spatula. Stainless Steel Sponge.
- 2 year parts warranty

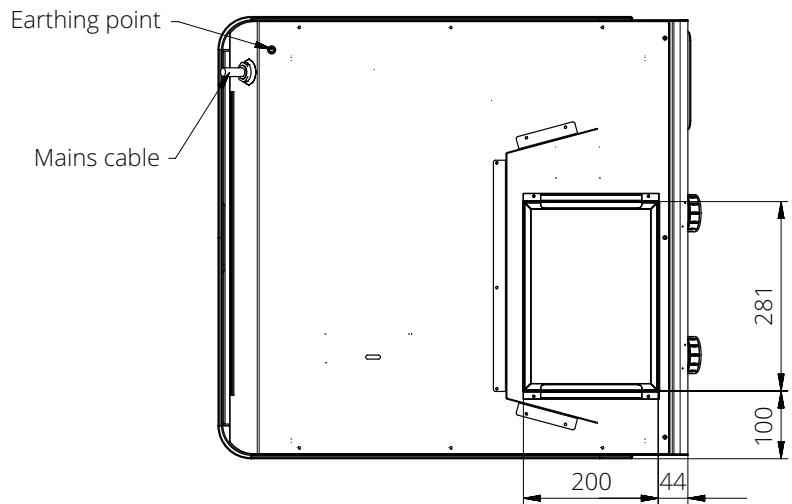
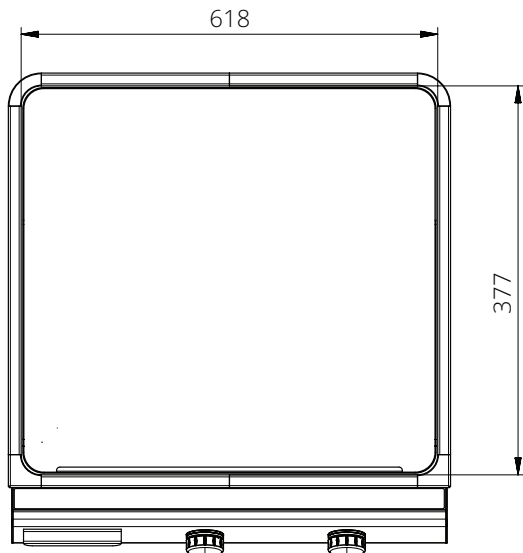
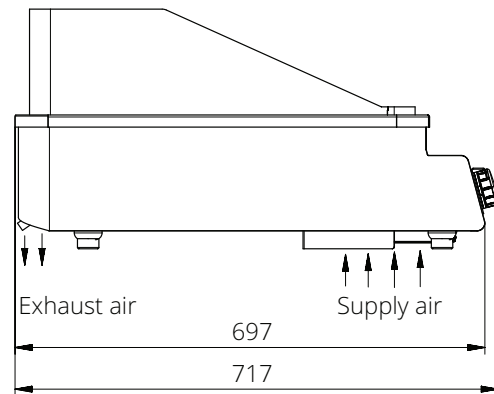
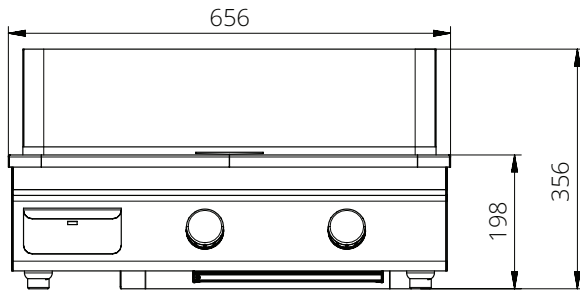

DIMENSIONS

656W x 717D x 198H mm (356mm with splash guard)

Weight: 48kg

TECHNICAL DATA

Total Output: 10kW

Power Supply: 3NAC 415V 50Hz
(Supplied with 1.8m cable, No Plug)

SHIPPING DATA

Shipping Weight: 68g

Shipping Dimensions: 510W x 1200D x 550H mm

SPECIFICATIONS ARE SUBJECT TO CHANGE WITHOUT NOTICE.

**INDUSTRY
KITCHENS**

www.industrykitchens.com.au 1800 611 058