

**1200mm WIDE RESTAURANT SERIES 2 BURNER
COMBINATION RANGE WITH 2 SPACE SAVER OVENS**

The Garland Heavy Duty Restaurant Series is a commercial range that has been engineered for unmatched performance and durability.

Garland's exclusive cast-iron Starfire Pro® burners combine speed with precision and even heat distribution to improve efficiency and control. All of the burners in the range are made of cast-iron for better heat retention and lasting durability.

Featuring stainless steel construction with a large front 127mm 'plate rail' and backguard that matches the other Restaurant Series units giving a sleek clean finish.

2 piece burners are easy to remove and clean with protected individual pilot lights and flame failure as standard. Large 686mm deep work surface fits six 300mm pots easily and grate design allows pots to slide across the surface easily. Premium 15mm thick griddle with powerful cast iron 'H' burners for even heat distribution.

Large easy-to-use control knobs sit atop the fully porcelain interior space saver ovens that accepts full sized sheet pans, has a 33.7MJ 'H' burner with flame failure and a strong adjustable door.



GF48-8LL pictured

STANDARD FEATURES

- Piezo ignition for all concealed burners
- Manual ignition for all open burners
- 300mm stamped drip tray w/dimpled bottom
- 108mm wide grease trough
- Gas regulator
- 152mm Adjustable stainless steel legs
- Two oven racks included as standard
- Available in Natural or Propane Gas

OPTIONAL FEATURES

- Fixed Height Castors - GF-CSTR (Non Brake) GF-CSTRB (brake)
- Grooved Griddle in 300mm sections - Specify -GRV
- Electronic ignition - Specify GFE48 (240V, 1P, 10A lead & plug not included)
- Flexible gas hose with quick disconnect and restraining kit - 432018-1200HK

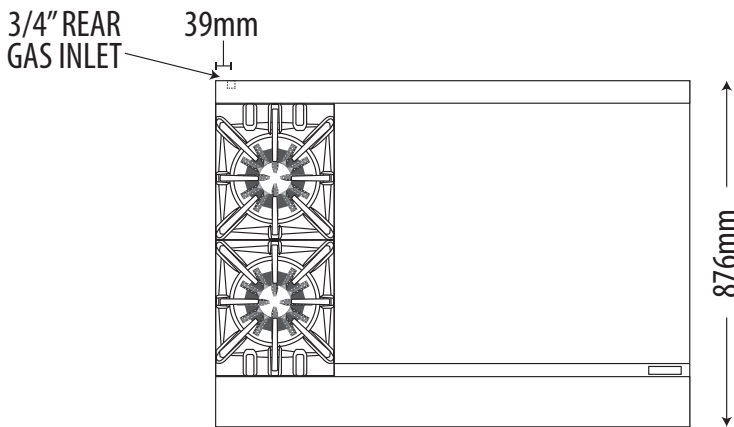
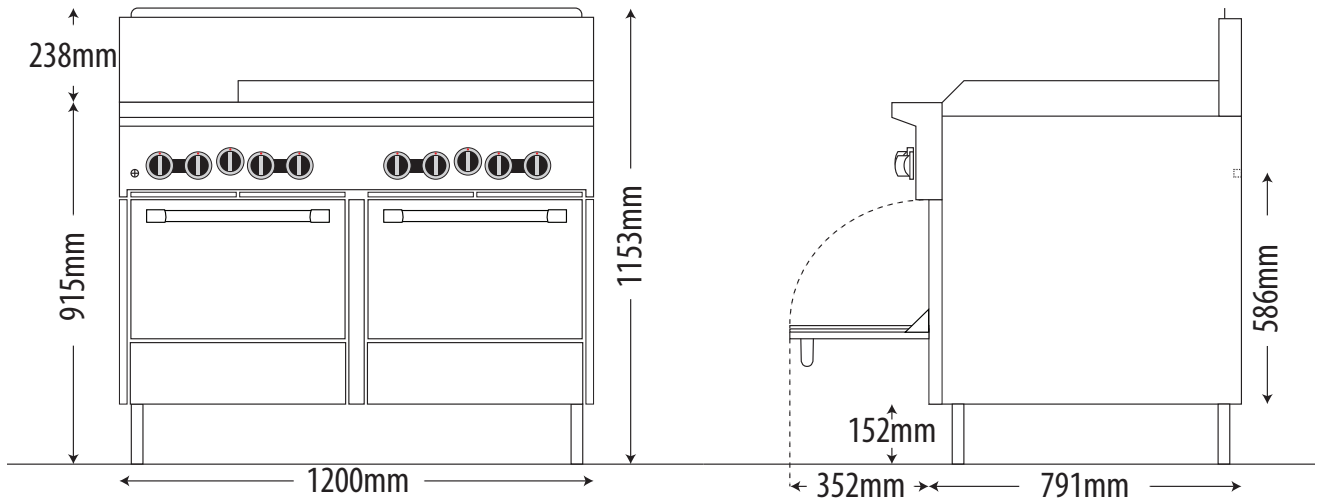
DIMENSIONS

- External Dimension: 1200W x 876D x 1153H mm
- Working height : 915mm
- Oven Interior : 508W x 660D x 330H mm
- Griddle : 900W x 585D mm
- Combustible wall clearance: Side: 356mm, Rear: 152mm

TECHNICAL DATA

Gas Type: Natural or Propane		
Total Output:	Natural 185.6MJ	Propane 167MJ
Burner Ratings:	Natural	Propane
Open Burner	30.6MJ	28.5MJ
Griddle per 300mm	19MJ	18MJ
Oven	33.7MJ	28MJ

Gas Connection: 3/4"

SHIPPING DATA

- Shipping weight: 305kg
- Shipping Dimensions: 1651W x 1143D x 1257H mm

AGA APPROVAL NUMBER

AGA 7455 G

SPECIFICATIONS ARE SUBJECT TO CHANGE WITHOUT NOTICE.