

900mm WIDE RESTAURANT SERIES 4 BURNER COMBINATION RANGE WITH STANDARD OVEN

The Garland Heavy Duty Restaurant Series is a commercial range that has been engineered for unmatched performance and durability.

Garland's exclusive cast-iron Starfire Pro® burners combine speed with precision and even heat distribution to improve efficiency and control. All of the burners in the range are made of cast-iron for better heat retention and lasting durability.

Featuring stainless steel construction with a large front 127mm 'plate rail' and backguard that matches the other Restaurant Series units giving a sleek clean finish.

Item GF36-4G12R is a combination range model with 4 burners, 300mm griddle and Standard Oven.

2 piece burners are easy to remove and clean with protected individual pilot lights and flame failure as standard. Large 686mm deep work surface fits four 300mm pots easily and grate design allows pots to slide across the surface easily. Premium 15mm thick griddle with powerful cast iron 'H' burners for even heat distribution.

Large easy-to-use control knobs sit atop the fully porcelain interior standard oven that accepts full sized sheet pans in both directions, has a for all concealed burners flame failure and a strong adjustable door.

STANDARD FEATURES

- 40MJ 'H' burner with Piezo ignition
- Manual ignition for all open burners
- 300mm stamped drip trays w/dimpled bottom
- Gas regulator
- 152mm Adjustable stainless steel legs
- Two oven racks included as standard
- Available in Natural or Propane Gas

OPTIONAL FEATURES

- Fixed Height Castors - GF-CSTR (Non Brake) GF-CSTRB (brake)
- Grooved Griddle in 300mm sections - Specify -GRV
- Electronic ignition - Specify GFE36 (240V,1P,10A lead & plug not included)
- Convection oven(s) - Specify GFE36-4G12C (240V,1P,10A lead & plug not included)
- Flexible gas hose with quick disconnect and restraining kit - 432018-1200HK

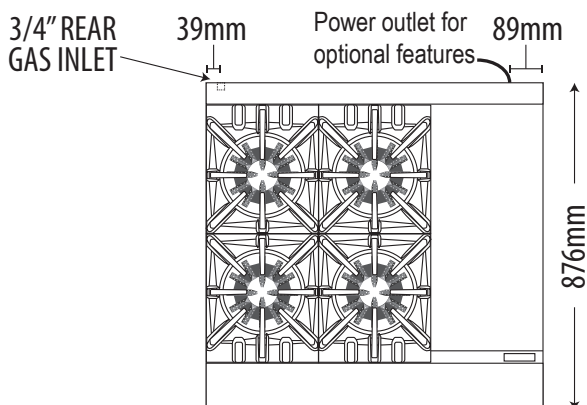
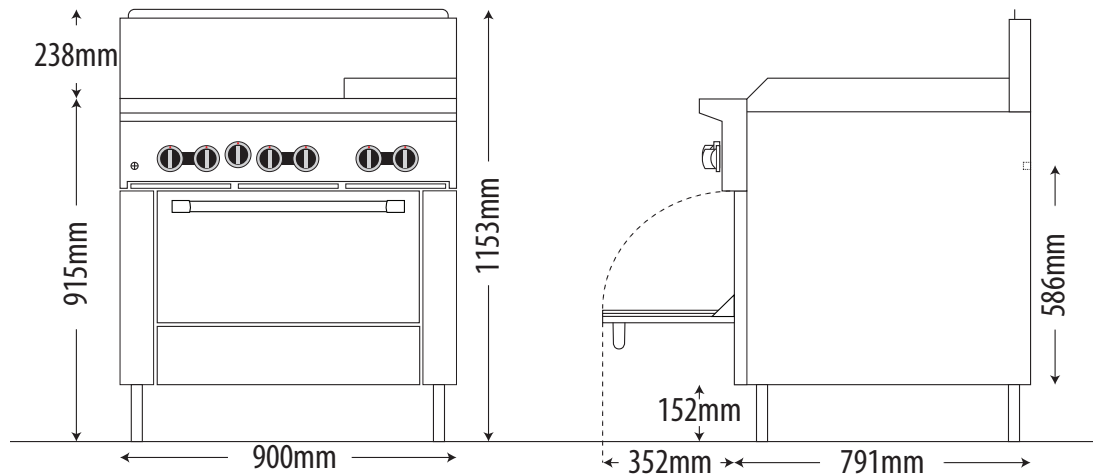
DIMENSIONS

External Dimension:	900W x 876D x 1153H mm	
Working height :	915mm	
Oven Interior :	667W x 660D x 330H mm	
Griddle :	600W x 585D mm	
Combustible wall clearance:	Side:	356mm, Rear: 152mm

TECHNICAL DATA

Gas Type:	Natural or Propane	
Total Output:	Natural	Propane
	181.4MJ	165MJ
Burner Ratings:	Natural	Propane
Open Burner	30.6MJ	28.5MJ
Griddle per 300mm	19MJ	18MJ
Oven	40MJ	33MJ
Gas Connection:	3/4"	

SHIPPING DATA

Shipping weight:	209kg
Shipping Dimensions:	1050W x 1050D x 1017H mm

AGA APPROVAL NUMBER

AGA 7455 G

SPECIFICATIONS ARE SUBJECT TO CHANGE WITHOUT NOTICE.