

**600mm WIDE RESTAURANT SERIES  
COMBINATION RANGE WITH SPACE SAVER OVEN**

The Garland Heavy Duty Restaurant Series is a commercial range engineered for unmatched performance and durability.

Garland's exclusive cast-iron Starfire Pro® burners combine speed with precision and even heat distribution to improve efficiency and control. All burners are made of cast-iron for better heat retention and lasting durability. Featuring stainless steel construction with a large front 127mm 'plate rail' and backguard that matches the other Restaurant Series units giving a sleek clean finish.

Item GF24-2G12L is a combination range model with 2 burners, 300mm griddle and Space Saver Oven.

2 piece burners are easy to remove and clean with protected individual pilot lights and flame failure as standard. Large 686mm deep work surface fits two 300mm pots easily and grate design allows pots to slide across the surface easily. Premium 15mm thick griddle with powerful cast iron 'H' burners for even heat distribution.

Large easy-to-use control knobs sit atop the fully porcelain interior space saver oven that accepts full sized sheet pans, has a 33.7MJ 'H' burner with flame failure and a strong adjustable door.

**STANDARD FEATURES**

- Piezo ignition for all concealed burners
- Manual ignition for all open burners
- 300mm stamped drip trays w/dimpled bottom
- Gas regulator
- 152mm Adjustable stainless steel legs
- Two oven racks included as standard
- Available in Natural or Propane Gas

**OPTIONAL FEATURES**

- Fixed Height Castors - GF-CSTR (Non Brake) GF-CSTRB (brake)
- Grooved Griddle in 300mm sections - -GRV
- Electronic ignition - Specify GFE24 (240V, 1P, 10A lead & plug not included)
- Flexible gas hose with quick disconnect and restraining kit - 432018-1200HK

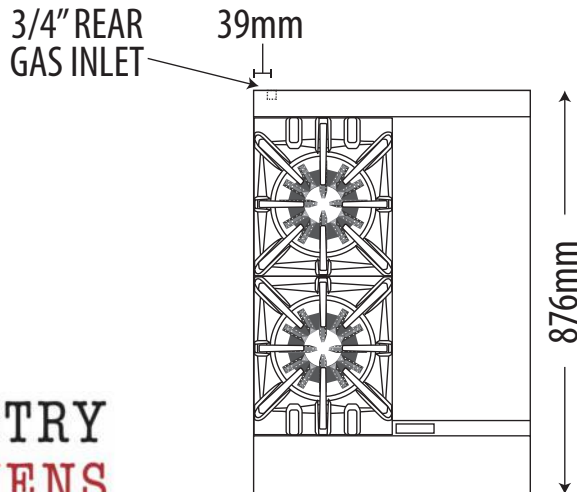
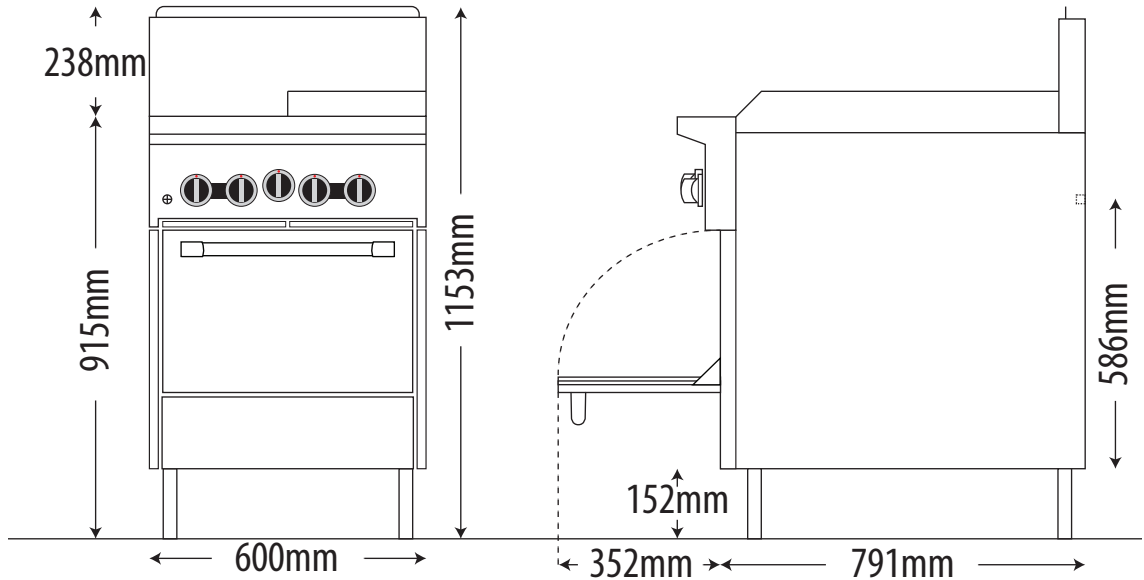
**DIMENSIONS**

External Dimension: 600W x 876D x 1153H mm

Working height : 915mm

Oven Interior : 508W x 660D x 330H mm

Griddle : 300W x 585D mm

Combustible wall clearance: Side: 356mm, Rear: 152mm

**TECHNICAL DATA**

Gas Type: Natural or Propane

Total Output:	Natural 113.9MJ	Propane 103MJ
---------------	--------------------	------------------

Burner Ratings:	Natural	Propane
Open Burner	30.6MJ	28.5MJ
Griddle per 300mm	19MJ	18MJ
Oven	33.7MJ	28MJ

Gas Connection: 3/4"

**SHIPPING DATA**

Shipping Weight: 151kg

Shipping Dimensions: 737W x 1041D x 1017H mm

**AGA APPROVAL NUMBER**

AGA 7455 G

SPECIFICATIONS ARE SUBJECT TO CHANGE WITHOUT NOTICE.

**INDUSTRY  
KITCHENS**

www.industrykitchens.com.au 1800 611 058