

The Frymaster CDC63 is a 32-litre stainless steel cleaning solution caddy designed to safely transport and dispose of fryer cleaning solutions in commercial kitchens. It supports the “boil-out” deep-cleaning process by making handling hot cleaning liquids safer and more efficient.

The caddy features a secure latching lid to help prevent spills, low-profile 50 mm castors for easy movement around the kitchen, and a ½-inch drain valve for controlled and convenient emptying.

Hot cleaning solutions should be cooled to 60-80°C before transporting to the disposal drain.

Not to be used for oil transport or disposal.

STANDARD FEATURES

- 32-litre capacity suitable for low-volume fryers and fryers up to 32 litres
- Tight-fitting, latching stainless steel lid for secure transport
- 50 mm low-profile castors with fold-down handle and low centre of gravity
- ½-inch drain pipe with integrated shut-off valve
- All-stainless steel construction for durability and corrosion resistance



DIMENSIONS

External:

291W x 714D x 808H mm

NET WEIGHT: 20kg

Shipping:

425W x 800D x 635H mm

WEIGHT: 56kg

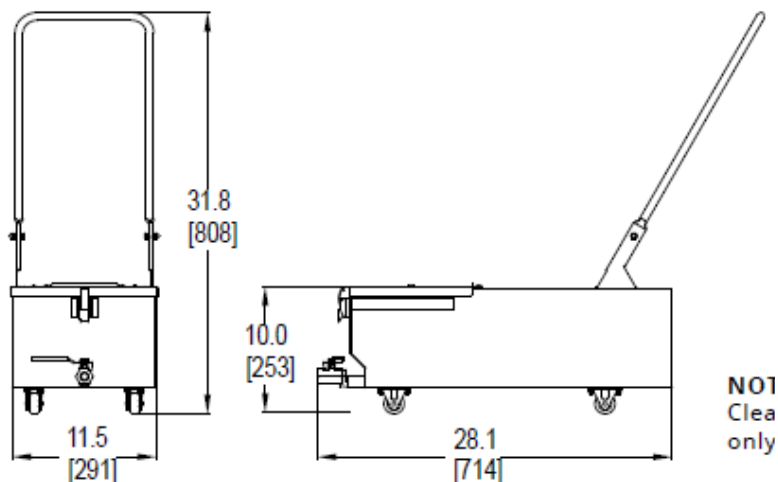

SPECIFICATIONS ARE SUBJECT TO CHANGE WITHOUT NOTICE.