

### WIDE BODY GAS FRYERS – 31 LITRE

Specifically designed for high volume/large surface area frying, Frymaster's 1814 gas fryers are designed for enhanced for improved efficiency, convenience and serviceability. The 1814G series have 31 litre oil capacity with 5 high powered tubular burners. The frying area is 457mm x 356mm x 95mm.

Smart design uses 12-20% less oil for 3 basket frypot compared to 25L fryers. The temperature sensor, mounted on the tubes, permits instant response to loads. Fully stainless steel frypot with wide cold zone is ideal for high sediment foods.

Available with and without filtration under cabinet.

#### STANDARD FEATURES

- Cold zone. 1-1/4" (32 mm) IPS ball type drain valve
- Tube frypot design - easy to clean
- Boil-out mode for easy cleaning
- Stainless steel frypot
- 3 baskets per frypot
- Available in 1 pot, no filtration or 1, 2, 3 Pot with filtration – ("GF" Models)
- Legs standard for single fryers, adjustable castors standard for filtration fryers
- Electronic Timer Controller
- Frypot Cover(s)

#### OPTIONAL FEATURES

- Castors (single fryers)
- Electronic Lane Controller (3 lane) programmable. - Suffix L
- CM3.5 Computer Controller - Suffix C
- Automatic basket lifts with CM3.5 Computer Controller - Suffix BLC
- Heater Tape - Suffix -HT
- Fish Plates - 2208966
- Other basket sizes - specify
- Front Oil Disposal with 108mm wand - Suffix -FD (Rear Oil Disposal -RD)



21814GF shown with computer controller

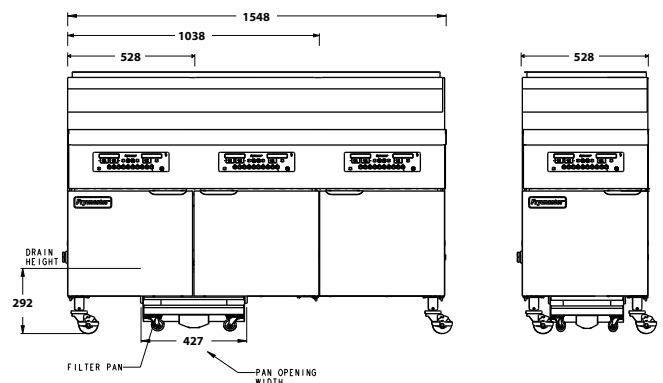
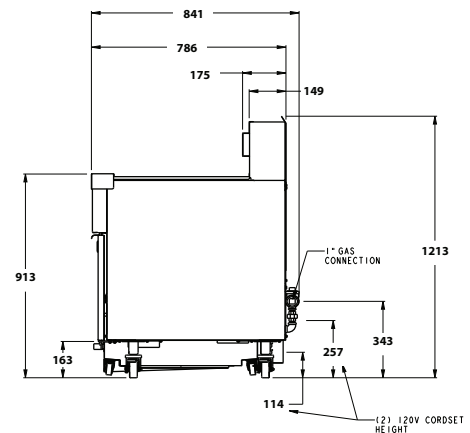
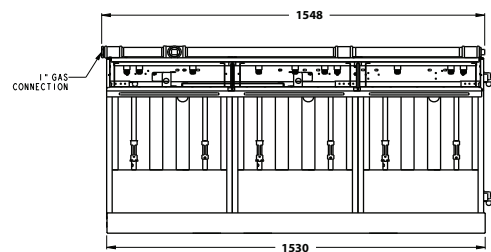

#### DIMENSIONS

External: 528W x 841D x 1213H mm (11814/GF)  
 1038W x 841D x 1213H (21814GF)  
 1548W x 841D x 1213H (31814GF)  
 Clearance: Sides and rear 152mm, Front 610mm  
 Net Weight: 116/177kg (11814/GF) , 293kg (21814GF), 408kg (31814GF)

#### TECHNICAL DATA

Power Supply: 240V, 1 Phase, 10A. (Supplied with 2m lead and plug)

Total Output:  
 Gas Supply: 117mj/hr - NG/Propane (per frypot)  
 Gas Connection: (refer table).  
 Drain Height: 292 mm

AGA Approval Number: AGA 9142 G

#### PRODUCTION CHIPS FROM FROZEN

36kg per hour (per pot)

#### CONTROLLER AS STANDARD

Electronic Timer

#### CLEARANCE

Sides: 152mm to combustible materials

#### SHIPPING DATA

Shipping Weight: 116kg/177kg (11814/GF)  
 Shipping Dimensions: 737W x 1067D x 1397H mm

Shipping Weight: 293kg (21814GF)  
 Shipping Dimensions: 1334W x 1067D x 1397H mm

Shipping Weight: 408kg (31814GF)  
 Shipping Dimensions: 1664W x 1067D x 1397H mm

SPECIFICATIONS ARE SUBJECT TO CHANGE WITHOUT NOTICE.

1814 Gas Connection Requirements	
Model	Gas Connection Size
11814	3/4"
21814	One 1"
31814	One 1"