

Flamic

**SF600DX1000, SF600DX1200,
SF600VDX1000, SF600VDX1200**

Floor Sheeter

MOFFAT

**INDUSTRY
KITCHENS**

www.industrykitchens.com.au 1800 611 058

Product Features

- Floor mounted
- Fixed or variable speed conveyor belt options
- Lever and foot pedal direction control
- Manual roller gap adjustment
- Digital display for lamination thickness
- Tables fold up when not in use
- Supplied with 2 rolling pins
- Conveyor belt width 600mm
- Table length 1000mm or 1200mm
- Roller diameter 70mm, roller gap 0.2 - 37mm



SF600DX1000

Whatever you need to sheet, Flamic have the solution. Small bench top sheeters to large floor sheeters, we satisfy the needs of small bakeries and large wholesale operations alike. Manufactured in Italy to the highest quality standards, Flamic sheeters provide excellent value for money and will bring a little "Italian flair" to your bakery. Engineered to last, the performance and reliability of Flamic sheeters will give you many years of trouble free operation.



SF600DX1000, SF600DX1200, SF600VDX1000, SF600VDX1200 Floor Sheeter

| Models | Dimensions (mm) | | | | | | | | |
|--------------|-----------------|------|-----|-----|------|------|------|------|-----|
| | A | B | D | E | F | G | H | I | L |
| SF600DX1000 | 2160 | 2490 | 900 | 920 | 1065 | 1225 | 1757 | 1180 | 800 |
| SF600DX1200 | 2560 | 2890 | 900 | 920 | 1065 | 1225 | 1940 | 1350 | 800 |
| SF600VDX1000 | 2160 | 2490 | 900 | 920 | 1065 | 1225 | 1757 | 1180 | 800 |
| SF600VDX1200 | 2560 | 2890 | 900 | 920 | 1065 | 1225 | 1940 | 1350 | 800 |

| Models | Table Width (mm) | Electrical Requirements | Belt Speed | Weight (kg) |
|--------------|------------------|------------------------------|------------|-------------|
| SF600DX1000 | 1000 | 400-415V,3P+E, 50Hz, 0.75kW | Fixed | 234 |
| SF600DX1200 | 1200 | 400-415V,3P+E, 50Hz, 0.75kW | Fixed | 244 |
| SF600VDX1000 | 1000 | 220-240 ,1P+N+E, 50Hz, 0.5kW | Variable | 234 |
| SF600VDX1200 | 1200 | 220-240 ,1P+N+E, 50Hz, 0.5kW | Variable | 244 |

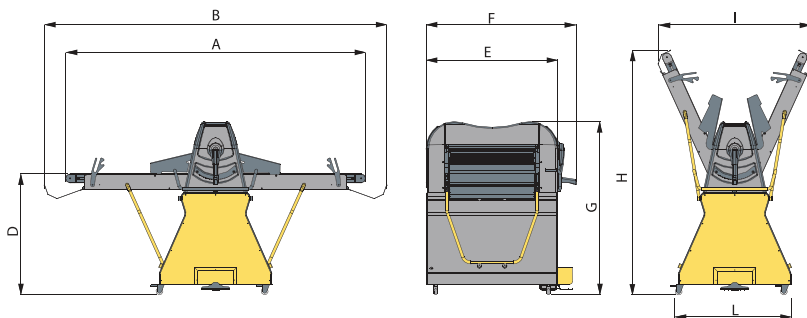

moффat.com.au
moффat.co.nz

Australia
moффat.com.au

Moffat Pty Limited

Victoria/Tasmania
740 Springvale Road
Mulgrave, Victoria 3170
Telephone +613-9518 3888
Facsimile +613-9518 3833
vsales@moffat.com.au

New South Wales
Telephone +612-8833 4111
nswsales@moffat.com.au

South Australia
Telephone +613-9518 3888
vsales@moffat.com.au

Queensland
Telephone +617-3630 8600
qldsales@moffat.com.au

Western Australia
Telephone +618-9413 2400
wasales@moffat.com.au

New Zealand
moффat.co.nz

Moffat Limited

Rolleston
45 Illinois Drive
Izone Business Hub
Rolleston 7675
Telephone +64 3-983 6600
Facsimile +64 3-983 6660
sales@moffat.co.nz

Auckland
Telephone +64 9-574 3150
sales@moffat.co.nz



In line with policy to continually develop and improve its products, Moffat Limited reserves the right to change specifications and design without notice. This specification sheet is meant for commercial purpose only. For technical documentation please refer to our service manuals.

© Copyright Moffat Ltd
AN.F01.21

an Ali Group Company



The Spirit of Excellence