



HOSHIZAKI

INDUSTRY KITCHENS

www.industrykitchens.com.au 1800 611 058

FT-156 MA-A

Undercounter Freezer

PRODUCT FEATURES

- Complete with stainless steel top.
- Standard with 4 shelves and 2 doors.
- Programmable electronic controller and display.
- 2 years parts and labour warranty.
- Comes standard with 4 x lockable (115 mm) castors (not legs).
- Optional Adjustable legs 150 - 180mm (Sold separately)

TECHNICAL DRAWING

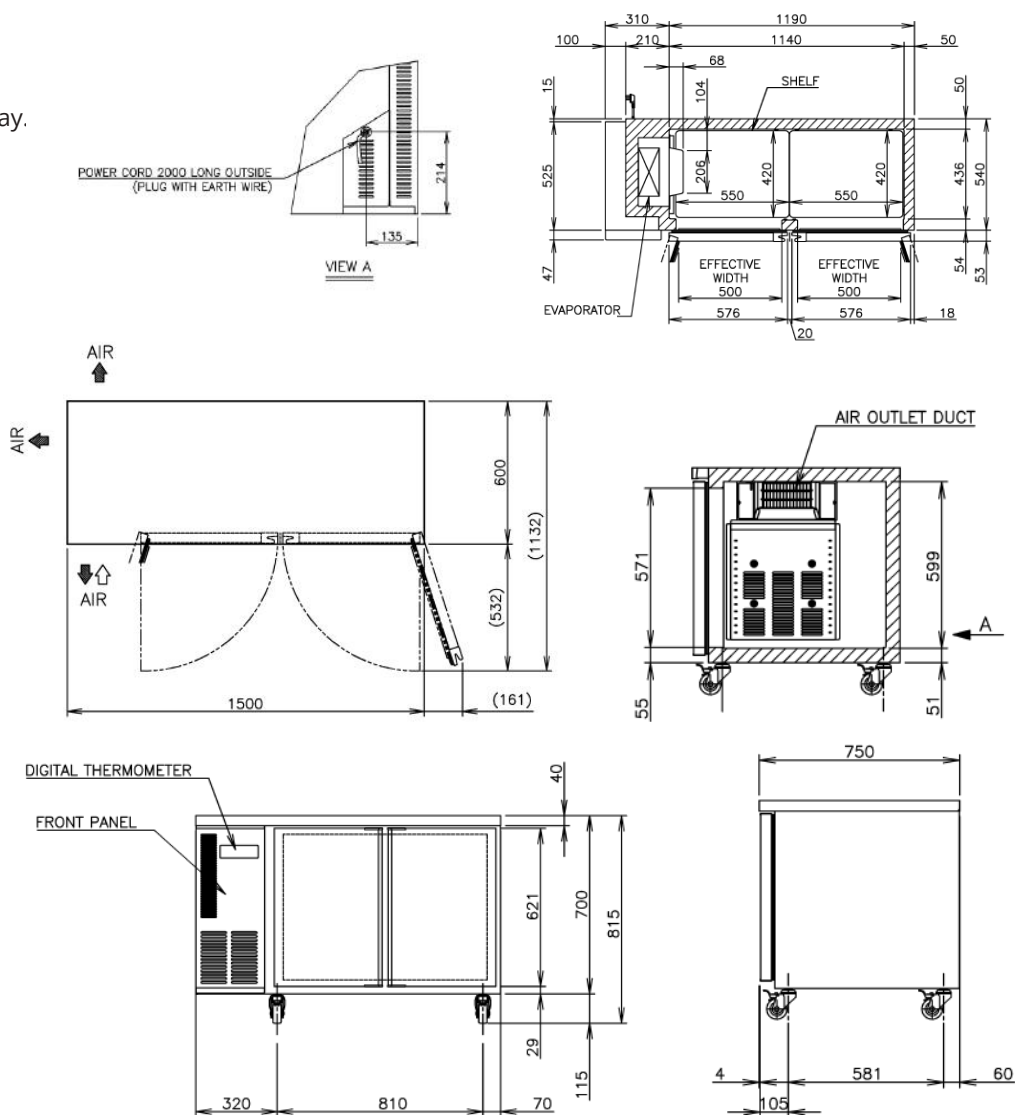

PRODUCT SPECIFICATION



Interior	Stainless Steel, ABS Plastic (Doors)
Exterior	Stainless steel, Galvanized Steel (Rear/Bottom), ABS plastic (Top & Bottom on Door)
Max Storage Capacity	318 L
Temperature Control	Microprocessor adjustable from -23°C to -7°C
Evaporator	Fin & Tube type
Outside Dimensions	1500mm(W)x600mm(D)x815mm(H)
Inside Dimensions	1140mm(W)x 436mm(D)x599mm(H)
Refrigeration System	Forced Air Circulation
Weight Net/Gross (kg)	81/86
AC Supply Voltage	1 phase 220 -240V 50Hz /10amp Plug
Amperage	Rated:2.6A
Refrigerant	R404A
Operating Conditions	Ambient Temp.: 5-43°C Voltage Range: Rated Voltage ±6%



Descriptions and specifications are subject to change at any time, without notice. Illustrations for demonstration purposes.

Copyright © 2020 Hoshizaki Lancer Pty Ltd. All right reserved. E&OE Date: Sept 2020